KXD980-TS28IP

KEXINDA Semiconductor reserves the right to make corrections, modifications, enhancements, improvements, and other changes to its products and services at any time.

- ◆ *To discontinue any product or service, KEXINDA should inform customers of that before 3 months through its homepage.*
- ◆ *Customers should obtain the latest relevant information before placing orders and should verify that such information is current and complete.*
- ◆ *The KEXINDA Semiconductor products listed in this document are intended for usage in general electronics applications. These KEXINDA Semiconductor products are neither intended nor warranted for usage in equipment that requires extraordinarily high quality and/or reliability or a malfunction or failure of which may cause loss of human life or bodily injury.*

Shenzhen Kexinda Electronics Co., Ltd.
All Rights Reserved



1 KXD980-TS28IP Overview

1.1 General Description

KXD980-TS28IP is a high-performance Touch Controller for capacitive touch keys. Its engine is an 8-bit 80C51 compatible Processor.

KXD980-TS28IP has three timer/counters, maximum 16-channel of touch sensors, maximum 24 programmable I/O pins, 12-channel 8-bit PWMs, Watchdog timer, POR (Power-On Reset), UART, two I²C, SPI, 16-channel 12-bit ADC and LVD (Low Voltage Detector) as peripherals. In addition, it contains an internal ring oscillator, which can generate the 48 MHz system clock signal instead of a crystal oscillator.

KXD980-TS28IP has its own architecture for fast sensing. With the hardware filter, it provides noise immunity and excellent sensitivity. The firmware algorithm supports smart sensitivity and compensates for any changes in the sensitivity due to environmental factors such as temperature and humidity.

To effectively manage power, KXD980-TS28IP enables low power consumption by using scan interval and clock control methods after last touch.

KXD980-TS28IP operates over the extended -20°C to +85°C temperature range, and is available in the 28-pin TSSOP package.

1.2 Features

- ◆ Capacitive touch key controller
 - Supports up to 16 single-type touch keys
 - Supports scroll bar-type touch keys
 - Supports wheel-type touch keys
- ◆ Response Time
 - Initial latency of < 20ms for first touch, subject to configuration
 - Programmable frame rate for power saving.
- ◆ CPU

- 8-bit Turbo 80C52 Architecture
- 4 Cycles / 1 Machine Cycle
- Instruction Level Compatible with Intel 80C52
- ◆ Memory
 - 16KB Flash (Including 1KB User EEPROM)
 - 512B Internal Aux. RAM
 - 256B Internal RAM
- ◆ Power Supply
 - Operating Voltage : +2.7V to +3.6V
- ◆ Operating Frequency: Max. 48MHz
- ◆ 24 Programmable I/O Pins
- ◆ 12-channel 8-bit PWMs
- ◆ Communication interfaces
 - 2-channel I2C Communication
 - 1-channel UART Communication
 - 1-channel SPI Communication
- ◆ 16-channel 12-bit ADC
- ◆ Internal Ring OSC with Calibration function
- ◆ Supporting ISP/IAP/MDS
- ◆ 10 Internal Interrupt Sources and 5 External Interrupt Sources
- ◆ 4 Reset Sources
- ◆ Power Down Wake-up Sources
 - Reset Sources + 5 External Interrupt (Both Levels)
 - Watchdog Timer Interrupt
- ◆ 3 operating modes : Active, Sleep, Deep Sleep
- ◆ E.S.D. Protection up to
 - 8,000V
- ◆ Latch-up Protection Up to $\pm 200\text{mA}$
- ◆ Package
 - 28-TSSOP



1.3 Applications

- ◆ Home appliance: TV, Monitor, Home Theater
- ◆ Mobile Phones
- ◆ Portable MP3, MP4
- ◆ Digital Cameras
- ◆ Battery power applications

1.4 Product Family Guide

Product	Touch Channels	Flash [Byte]	Package
KXD920-ML16IP	2	8K	4 x 4 mm, 0.85T, 16-pin MLF
KXD950-TS20IP	8	8K	20-pin TSSOP
KXD950-QF16IP	8	8K	3 x 3 mm, 0.85T, 16-pin QFN
KXD950-ML16IP	8	8K	4 x 4mm, 0.85T, 16-pin MLF
KXD951-ML16IP	8	8K	4 x 4 mm, 0.85T, 16-pin MLF
KXD960-QF16IP	7	12K	3 x 3 mm, 0.55T, 16-pin QFN
KXD970-ML24IP	8	12K	4 x 4 mm, 0.85T, 24-pin MLF
KXD971-ML24IP	8	12K	4 x 4 mm, 0.85T, 24-pin MLF
KXD980-TS28IP	16	16K	28-pin TSSOP
KXD980-SO28IP	16	16K	28-pin SOP
KXD980-ML24IP	16	16K	4 x 4 mm, 0.85T, 24-pin MLF
KXD990-ML32IP	16	32K	5 x 5 mm, 0.85T, 32-pin MLF

2 Block Diagram

Figure shows the block diagram of KXD980-TS28IP. Programs reside in the internal program memory (Embedded Flash Memory). Data are read from or written to data memory (SRAM) or special function registers (SFRs).

The internal registers of KXD980-TS28IP are configured as part of the on-chip RAM: therefore each register has an address. This is reasonable for KXD980-TS28IP, since it has so many registers.

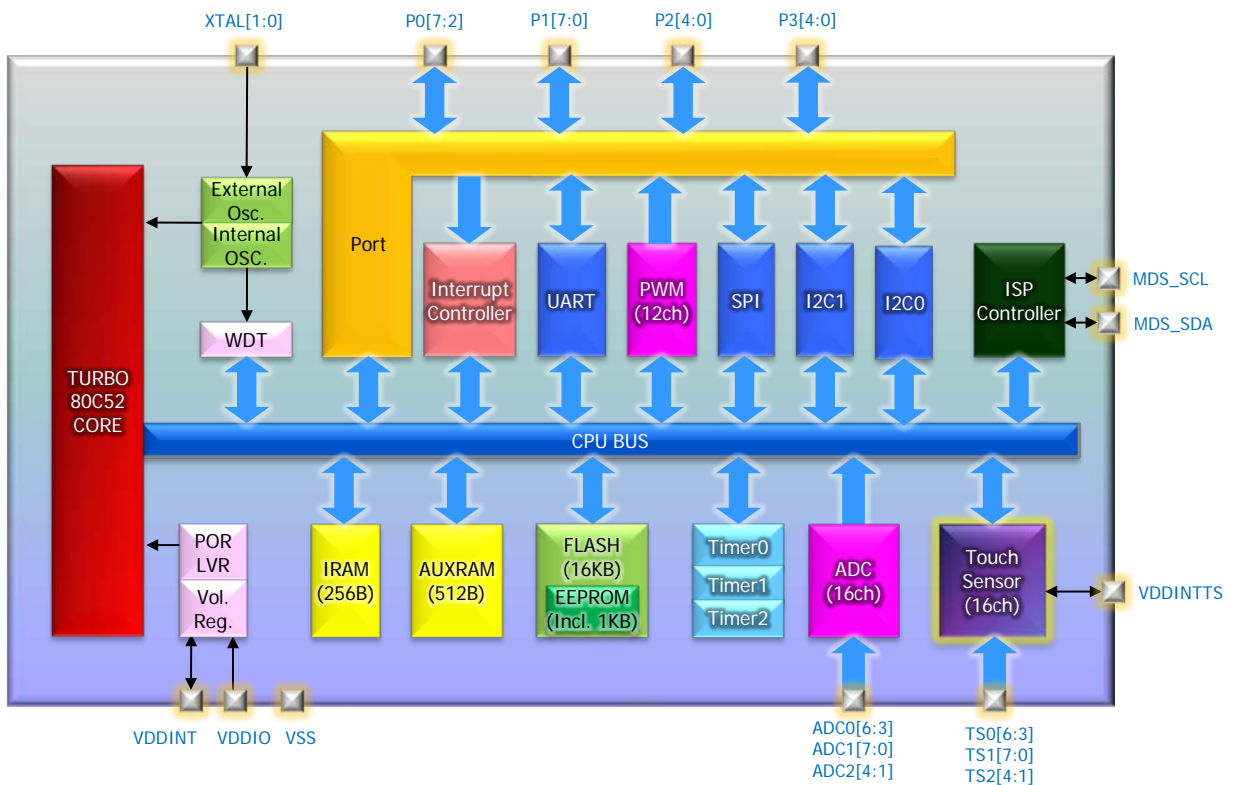

3 Pin Configuration

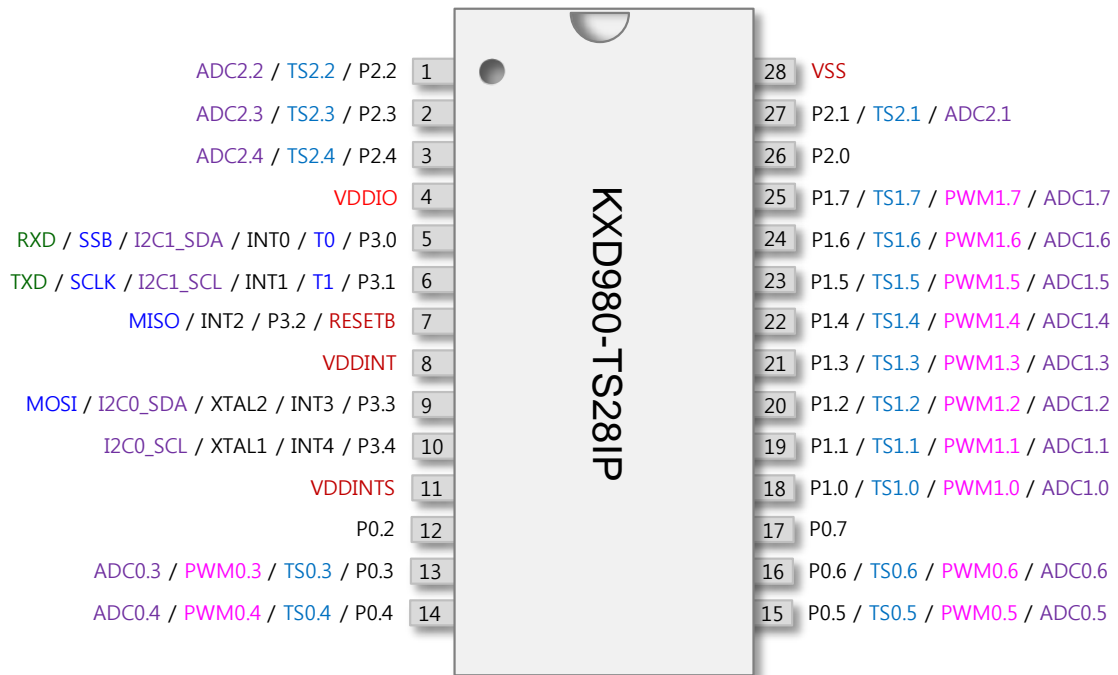

28-pin TSSOP Package Diagram

4 Pin Description

Pin No.	Name	Type	Description	Share Pins
1	TS2.2	I/O	Touch Sensing Channel 2.2	P2.2 / ADC2.2
2	TS2.3	I/O	Touch Sensing Channel 2.3	P2.3 / ADC2.3
3	TS2.4	I/O	Touch Sensing Channel 2.4	P2.4 / ADC2.4
4	VDDIO	PWR		
5	P3.0	I/O	General I/O Port 3.0	RXD / SSB / I2C1_SDA / INT0 / T0
6	P3.1	I/O	General I/O Port 3.1	TXD / SCLK / I2C1_SCL / INT1 / T1
7	P3.2	I/O	General I/O Port 3.2	INT2 / RESETB / MISO
8	VDDINT	O	Digital Power Filter (+1.8V)	
9	P3.3	I/O	General I/O Port 3.3	INT3 / XTAL2 / I2C0_SDA / MOSI
10	P3.4	I/O	General I/O Port 3.4	INT4 / XTAL1 / I2C0_SCL
11	VDDINTS	O	Touch Sensor Power Filter	
12	P0.2	I/O	General I/O Port 0.2	
13	TS0.3	I/O	Touch Sensing Channel 0.3	P0.3 / PWM0.3 / ADC0.3
14	TS0.4	I/O	Touch Sensing Channel 0.4	P0.4 / PWM0.4 / ADC0.4
15	TS0.5	I/O	Touch Sensing Channel 0.5	P0.5 / PWM0.5 / ADC0.5
16	TS0.6	I/O	Touch Sensing Channel 0.6	P0.6 / PWM0.6 / ADC0.6
17	P0.7	I/O	General I/O Port 0.7	
18	TS1.0	I/O	Touch Sensing Channel 1.0	P1.0 / PWM1.0 / ADC1.0
19	TS1.1	I/O	Touch Sensing Channel 1.1	P1.1 / PWM1.1 / ADC1.1
20	TS1.2	I/O	Touch Sensing Channel 1.2	P1.2 / PWM1.2 / ADC1.2
21	TS1.3	I/O	Touch Sensing Channel 1.3	P1.3 / PWM1.3 / ADC1.3
22	TS1.4	I/O	Touch Sensing Channel 1.4	P1.4 / PWM1.4 / ADC1.4
23	TS1.5	I/O	Touch Sensing Channel 1.5	P1.5 / PWM1.5 / ADC1.5
24	TS1.6	I/O	Touch Sensing Channel 1.6	P1.6 / PWM1.6 / ADC1.6
25	TS1.7	I/O	Touch Sensing Channel 1.7	P1.7 / PWM1.7 / ADC1.7
26	P2.0	I/O	General I/O Port 2.0	
27	TS2.1	I/O	Touch Sensing Channel 2.1	P2.1 / ADC2.1
28	VSS	GND		

5 Absolute Maximum Ratings

.Absolute Maximum Ratings(TA = 25 °C)

Item	Conditions	Range
DC Voltage in V _{DDIO} relative to Ground	-	-0.5 V to +4.6V
DC Input Voltage	-	-0.5V to (V _{DDIO} +0.5V)
DC Output Voltage	-	-0.5 V to (V _{DDIO} +0.5V)
DC Output Current High	One I/O pin active	-25mA
	All I/O pin active	-100mA
DC Output Current Low	One I/O pin active	+30mA
	All I/O pin active	+150mA
Storage Temperature	-	-65 °C to +150 °C
Soldering Temperature	-	260 °C for 10 seconds

.Recommended Operating Conditions

Item	Conditions	Range
Operating Voltage	-	+2.7 V to +3.6V
Operating Temperature	-	-20 °C to + 85 °C

6 DC Characteristics

* $T_A = -20^{\circ}\text{C} \sim +85^{\circ}\text{C}$, $V_{DDIO} = 2.7\text{V} \sim 3.6\text{V}$ unless otherwise specified

Parameter	Symbol	Pin	Conditions	Value			Unit
				Min.	Typ.	Max.	
Input Low Voltage	V_{IL}	P0,P1,P2,P3	$V_{DDIO} = 2.7\text{V} \sim 3.6\text{V}$	-0.5	-	$0.2V_{DDIO} + 0.1$	V
Input high Voltage	V_{IH}	P0,P1,P2,P3	$V_{DDIO} = 2.7\text{V} \sim 3.6\text{V}$	$0.2V_{DDIO} + 1.0$	-	$V_{DDIO} + 0.5$	V
Output Low Voltage	V_{OL}	P0,P1,P2,P3	$V_{DDIO} = 3.0\text{V} \sim 3.6\text{V}$ ($I_{OL} = 4.35\text{mA}$) $V_{DDIO} = 2.7\text{V} \sim 3.0\text{V}$ ($I_{OL} = 3.55\text{mA}$)	-	-	$0.3V_{DDIO}$	V
		P0,P1,P2,P3[1:0] (High Drive)	$V_{DDIO} = 3.0\text{V} \sim 3.6\text{V}$ ($I_{OL} = 34.79\text{mA}$) $V_{DDIO} = 2.7\text{V} \sim 3.0\text{V}$ ($I_{OL} = 28.41\text{mA}$)	-	-	$0.3V_{DDIO}$	V
Output High Voltage	V_{OH}	P0,P1,P2,P3	$V_{DDIO} = 3.0\text{V} \sim 3.6\text{V}$ ($I_{OH} = -8.04\text{mA}$) $V_{DDIO} = 2.7\text{V} \sim 3.0\text{V}$ ($I_{OH} = -6.62\text{mA}$)	$0.7V_{DDIO}$	-	-	V
	V_{OHP}	P0,P1,P2,P3 (Pull-up Resistor Only)	$V_{DDIO} = 3.0\text{V} \sim 3.6\text{V}$ ($I_{OHP} = -30.30\mu\text{A}$) $V_{DDIO} = 2.7\text{V} \sim 3.0\text{V}$ ($I_{OHP} = -24.26\mu\text{A}$)	$0.7V_{DDIO}$	-	-	V
Logical 1 to 0 Transition Current	I_{TL}	P0,P1,P2,P3	$V_{DDIO} = 3.0\text{V} \pm 10\%$ ($V_{IN} = 2\text{V}$)	-	-	-650	μA
Input Leakage Current	I_{IL}	P0,P1,P2,P3	$V_{IN} = V_{IH}$ or V_{IL}	-	-	± 1	μA
Pin Capacitance	C_{IO}	All	$V_{DDIO} = 3.0\text{V}$	-	10	-	pF

7 AC Characteristics

* $T_A = -20\text{ }^{\circ}\text{C} \sim +85\text{ }^{\circ}\text{C}$, $V_{DDIO} = 2.7\text{V} \sim 3.6\text{V}$ unless otherwise specified

Parameter	Symbol	Pin	Conditions	Value			Unit
				Min	Typ	Max	
RESETB Input Width	t_{RST}	RESETB	$V_{DDIO} = 3\text{V} \pm 10\%$	24	-	-	F _{sys}
External Interrupt Input Width	t_{INT}	External Interrupt	$V_{DDIO} = 3\text{V} \pm 10\%$	4	-	-	F _{sys}

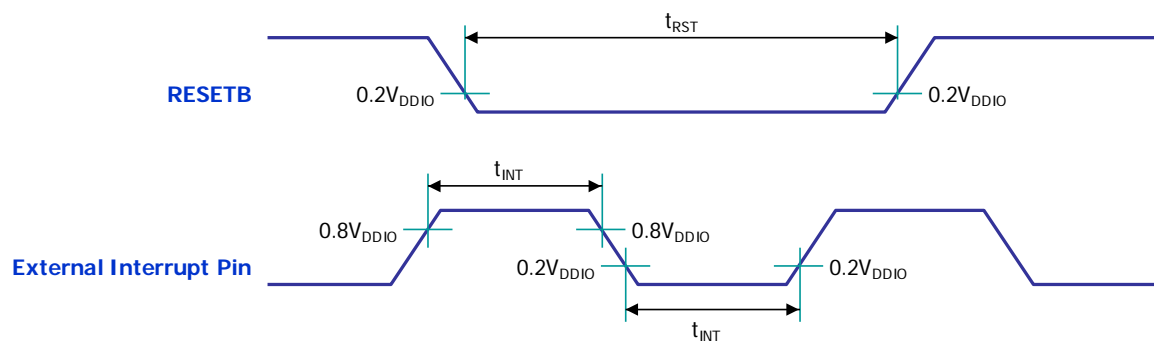

8 I2C Timing Characteristics

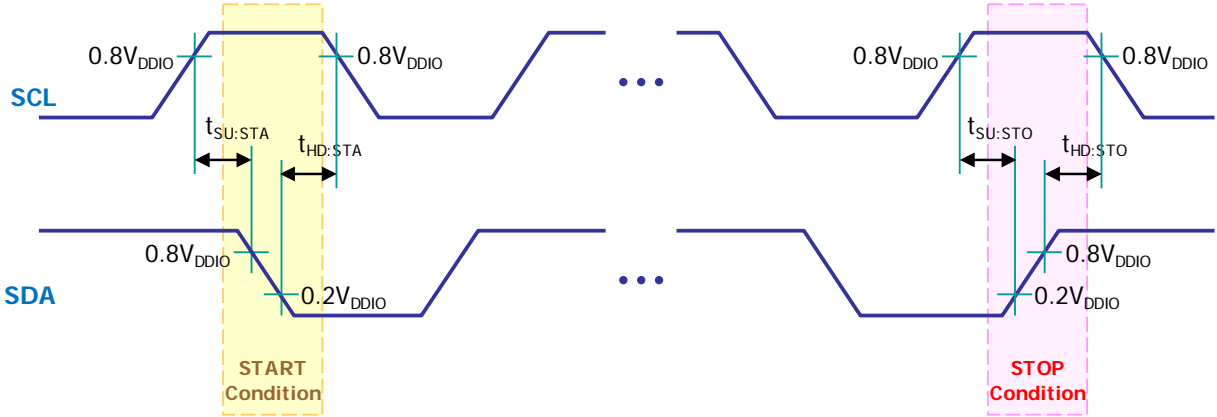

Symbol	Characteristics		Min. [ns]	Max. [ns]	Conditions
$t_{SU:STA}$	START Condition Setup Time	100kHz Mode	4,700	-	Only relevant for repeated START condition
		400kHz Mode	600	-	
$t_{HD:STA}$	START Condition Hold Time	100kHz Mode	4,700	-	After this period, the first clock pulse is generated
		400kHz Mode	600	-	
$t_{SU:STO}$	STOP Condition Setup Time	100kHz Mode	4,700	-	
		400kHz Mode	600	-	
$t_{HD:STO}$	STOP Condition Hold Time	100kHz Mode	4,700	-	
		400kHz Mode	600	-	

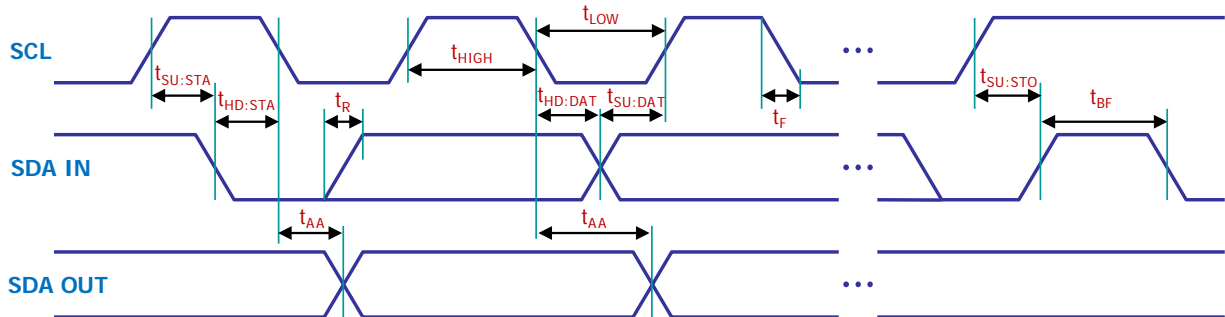

Symbol	Characteristics		Min. [ns]	Max. [ns]	Conditions
t_{HIGH}	Clock High Time	100kHz Mode	4,000	-	Minimum Frequency : 1MHz
		400kHz Mode	600	-	Minimum Frequency : 5MHz
t_{LOW}	Clock Low Time	100kHz Mode	4,700	-	Minimum Frequency : 1MHz
		400kHz Mode	1,300	-	Minimum Frequency : 5MHz
$t_{SU:DAT}$	Data Input Setup Time	100kHz Mode	250	-	
		400kHz Mode	100	-	
$t_{HD:DAT}$	Data Input Hold Time	100kHz Mode	0	-	
		400kHz Mode	0	900	
t_{AA}	Data Valid from Clock	100kHz Mode	-	3,500	
		400kHz Mode	-	-	
t_{BF}	BUS Free Time	100kHz Mode	4,700	-	
		400kHz Mode	1,300	-	
t_R	SDA & SCL Rising Time	100kHz Mode	-	1,000	The Range of Cb is from 10pF to 400pF
		400kHz Mode	$2.0 + 0.1C_b$	300	
t_F	SDA & SCL Falling Time	100kHz Mode	-	300	The Range of Cb is from 10pF to 400pF
		400kHz Mode	$2.0 + 0.1C_b$	300	

9 SPI Timing Characteristics

9.1 Master Mode

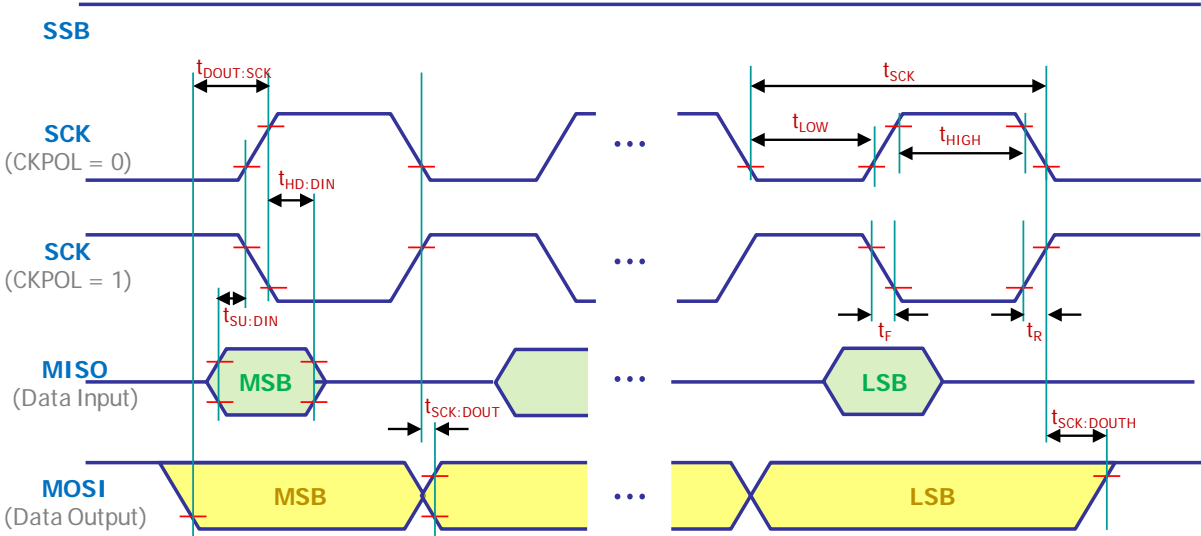

Symbol	Description	Mode	Min. [ns]	Typ. [ns]	Max. [ns]
t_{SCK}	SCK Period Time (using SFR 'SPICK')	Master	-	$F_{osc}/2 \sim F_{osc}/256$	-
t_{HIGH}, t_{LOW}	SCK High / Low	Master	-	50% Duty Cycle	-
t_F, t_R	SCK Rise / Fall Time	Master	-	3.6	-
$t_{SU: DIN}$	Data Input Setup Time	Master	-	10	-
$t_{HD: DIN}$	Data Input Hold Time	Master	-	10	-
$t_{DOUT:SCK}$	Data Output to SCK	Master	-	$0.5 \times t_{SCK}$	-
$t_{SCK: DOUT}$	SCK to Data Output	Master	-	10	-
$t_{SCK: DOUTH}$	SCK to Data Output High	Master	-	10	-

9.2 Slave Mode

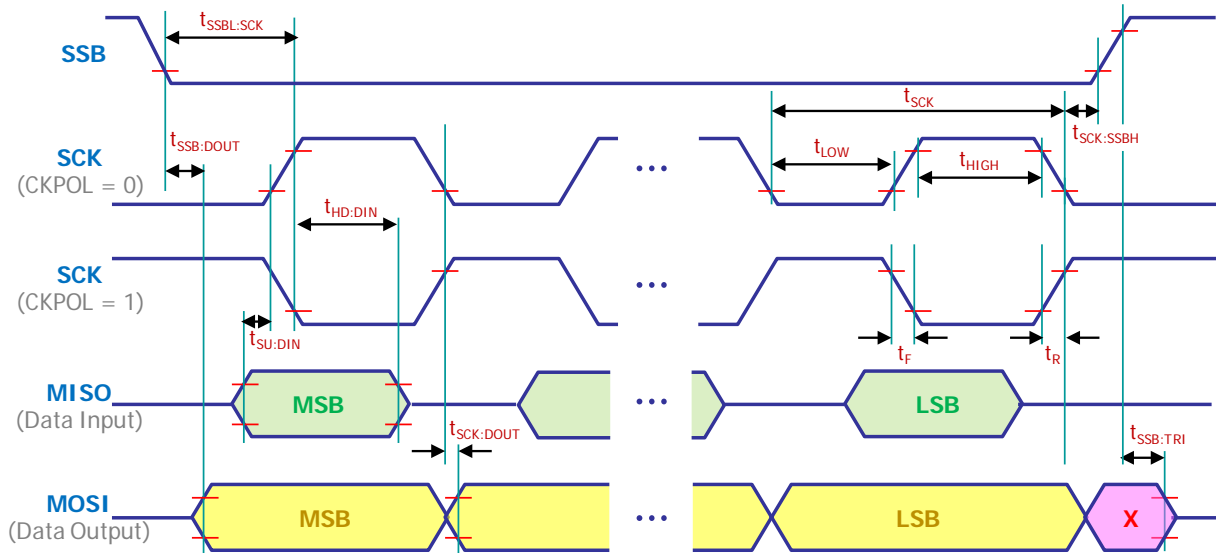

Symbol	Description	Mode	Min. [ns]	Typ. [ns]	Max. [ns]
$t_{SSB:DOUT}$	SSB Low to Data Output	Slave	-	15	-
T_{SCK}	SCK Period Time	Slave	$4 \times t_{sys}$	-	-
t_{HIGH} , t_{LOW}	SCK High / Low	Slave	$2 \times t_{sys}$	-	-
t_F , t_R	SCK Rise / Fall Time	Slave	-	1,600	-
$t_{SU:DIN}$	Data Input Setup Time	Slave	10	-	-
$t_{HD:DIN}$	Data Input Hold Time	Slave	t_{sys}	-	-
$t_{SCK:DOUT}$	SCK to Data Output	Slave	-	15	-
$t_{SCK:SSBH}$	SCK to SSB High	Slave	20	-	-
$t_{SSB:TRI}$	SSB High to Tri-state	Slave	-	10	-
$t_{SSBL:SCK}$	SSB Low to SCK	Slave	20	-	-

10 28-pin TSSOP Package Dimension

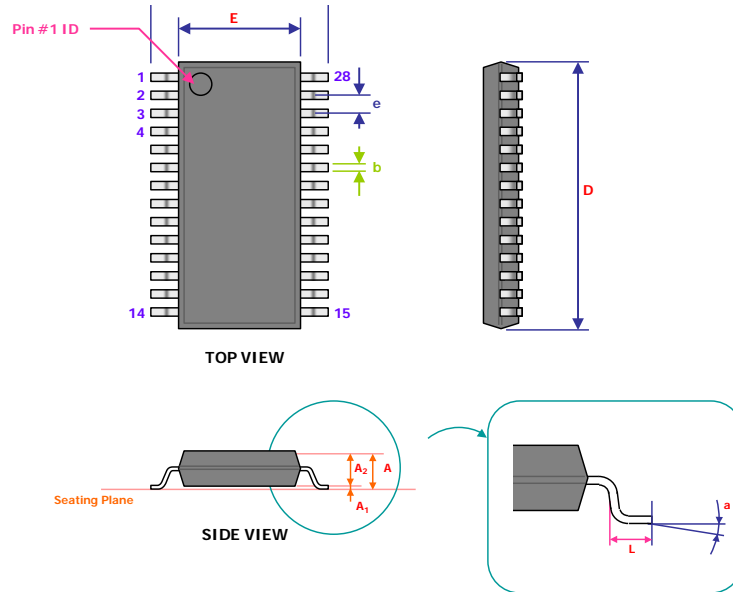

Symbol	Dimensions [mm]		
	Min.	Nom.	Max.
A	-	-	1.20
A ₁	0.05	-	0.15
A ₂	0.80	-	1.00
D	9.60	-	9.80
E	4.30	-	4.50
E ₁	6.25	-	6.55
B	0.19	-	0.30
E	0.65 BSC		
L	0.50	0.60	0.70
a	1°	-	7°

Notes:

1. All Dimension are in mm. Angles in Degrees.
2. Dimension b applies to Plated Terminal & is measured.
3. BSC : Basic Dimension. Theoretically exact value shown without tolerances.
REF : Reference Dimension, Usually without tolerance, for information purpose only.

1

2

3

4

5

6

7

KXD980_TSSOP28/SOP28

>> VDDIO (Operating Voltage) : +2.7V to +3.6V

J1
HEADER_6PIN_IROW

① I2C_SDA [1]
② I2C_SCL [1]
③ INT1 [1]
④ RESETB

VDDIO

ISP download
External interface

[1] LED1 >> R14 1K
[1] LED2 >> R15 1K
[1] LED3 >> R16 1K
[1] LED4 >> R17 1K
[1] LED5 >> R18 1K
[1] LED6 >> R19 1K
[1] LED7 >>

8 CHANNEL Touch PAD

PAD3, PAD1, PAD2, PAD4, PAD5, PAD6, PAD7, PAD8

IC1: KXD980_TSSOP28/SOP28

Internal components: VSS, ADC2.1/TS2.1/P2.1, P2.0, ACC1.7/PWM1.7/TS1.7/P1.7, ACC1.6/PWM1.6/TS1.6/P1.6, ACC1.5/PWM1.5/TS1.5/P1.5, ACC1.4/PWM1.4/TS1.4/P1.4, ACC1.3/PWM1.3/TS1.3/P1.3, ACC1.2/PWM1.2/TS1.2/P1.2, ACC1.1/PWM1.1/TS1.1/P1.1, ACC1.0/PWM1.0/TS1.0/P1.0, P0.7, ADC0.6/PWM0.6/TS0.6/P0.6, ADC0.5/PWM0.5/TS0.5/P0.5

External components: R3 560, R4 560, R5 560, R6 560, R7 560, R8 560, R9 2.2k, R10 2.2k, R11 560, R13 560, C1 1uF, C2 1uF, C3 0.1uF, C4 2.2uF, D1-D7, LED1-LED7

GPIOs: GPIO2, GPIO3, GPIO6, GPIO1, GPIO4

INT1, INT2, INT3, INT4, INT1/INT2/MISO, RESETB/P3.2/INT2/MISO, VDDINT, P3.3/INT3/XTAL2/I2C0_SDA/MOSI, P3.4/INT4/XTAL1/I2C0_SCL, VDDINTS, P0.2, P0.3/TS0.3/PWM0.3/ADC0.3, P0.4/TS0.4/PWM0.4/ADC0.4

E

D

C

B

A

NO.	REVISION NO.	QUANTITY			PART NO.	DESCRIPTION	MATERIAL	COLOR FINISH	NOTE
		C	B	A					
1									
2									
					SCALE	UNIT			
					A3	mm			
					NO.	DATE			
					2014-07-21				
					1	1			
					SHEET				
					Shenzhen Kexinda Electronics Co., Ltd.				