

THERMOMETER SPECIFICATION

Contents :

- General Description :3
- Features :3
- Block Diagram :4
- Pad Description :5
- Electrical Parameter :6
- Function Description :7
-8
- LCD Pattern :9
- Application Circuit :10
- PAD Location :11
- Function Flow Chart :12
- Order Information :13
- Revise History :13

• General Description :

The TCP310 is an one-decimal electronic clinical thermometer IC. It can push switch to select the °C/°F mode.

• Features :

- ✧ Single 1.5V Battery Power-Supply
- ✧ Automatic Power-OFF Function
- ✧ Built-in Low-Voltage Detector Function
- TCP310A : 1.30 ± 0.05V**
- TCP310B : 1.25 ± 0.05V**
- ✧ Measurement Range : 32.0°C ~ 42.9°C (90.0°F ~ 109.9°F)
- ✧ Measurement Accuracy : ± 0.1°C (± 0.2°F)
- ✧ Resolution : 0.1°C (0.1°F)
- ✧ Highest Temperature Hold
- ✧ **Fever-Alarm Function** : Temperature ≥ 37.8 °C (**100.0** °F)
- ✧ **Memory Function** : Display the Last Measuring Temperature.
- ✧ Bonding-Option for Stable Time Selection : 4s / 8s / 16s / 32s
- ✧ Bonding-Option for Buzzer Alarm Frequency : 4KHz / 5.3KHz / 6.4KHz / 8KHz
- ✧ Bonding-Option for °C and °F
- ✧ Bonding-Option for °C/°F Changeable or not Change Mode by Pushing-Switch
- ✧ When °C/°F Changeable Mode , Push ON/OFF Button to Select °C/°F and Bonding-Option °C or °F when Power-ON Initial

• Block Diagram :

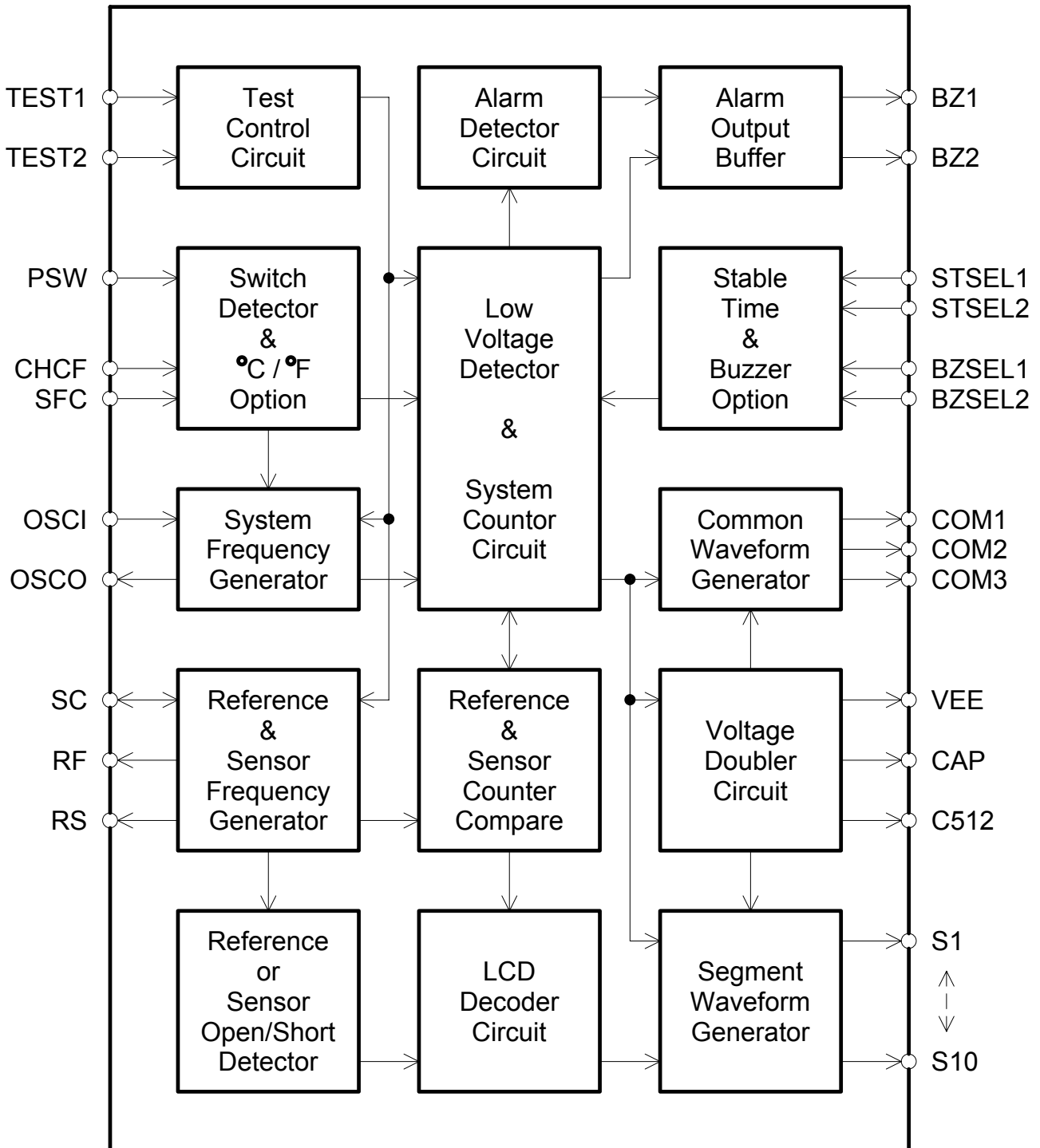

• Pad Description :

Pad No.	Pad Name	I/O	Description															
1~10	S1~S10	O	LCD Segment Driver , Connect to LCD															
11	VEE	O	Generated - 1.5V Voltage(VDD=1.5V)															
12	CAP	O	For Negative Voltage Pumping															
13	C512	O	For Negative Voltage Pumping															
14	TEST1	I	Test-Pad , for IC Test Only															
15	SFC	I	Bonding-Option for °C or °F Mode SFC= VDD or Open : °C (When °C/°F Change Mode , Power-ON is °C) SFC= VSS : °F (When °C/°F Change Mode , Power-ON is °F)															
16	CHCF	I	Bonding-Option for °C/°F Changeable or not Changeable Mode CHCF= VDD or Open : °C/°F Not Changeable Mode CHCF= VSS : °C/°F Changeable Mode															
17	VSS	P	Negative Power-Supply															
18	SC	I/O	Reference and Sensor Frequency															
19	RF	O	Connect to Reference Resistor															
20	RS	O	Connect to Sensor Resistor															
21	VDD	P	Positive Power-Supply															
22	PSW	I	Pull-High Input Pad , Push-Switch to Power-ON or Power-OFF															
23	TEST2	I	Pull-High Input Pad , for the Test of Production TEST2= VDD or Open : LCD Display the Highest Value TEST2= VSS : LCD Display the Real-Time Value															
24 25	BZSEL1 BZSEL2	I I	Pull-High Input Pad , Bonding-Option for Buzzer Output Frequency : <table border="1" style="margin-left: 20px;"> <thead> <tr> <th>BZ Freq.</th> <th>BZSEL1</th> <th>BZSEL2</th> </tr> </thead> <tbody> <tr> <td>8.0KHz</td> <td>VDD or Open</td> <td>VDD or Open</td> </tr> <tr> <td>6.4KHz</td> <td>VSS</td> <td>VDD or Open</td> </tr> <tr> <td>5.3KHz</td> <td>VDD or Open</td> <td>VSS</td> </tr> <tr> <td>4.0KHz</td> <td>VSS</td> <td>VSS</td> </tr> </tbody> </table>	BZ Freq.	BZSEL1	BZSEL2	8.0KHz	VDD or Open	VDD or Open	6.4KHz	VSS	VDD or Open	5.3KHz	VDD or Open	VSS	4.0KHz	VSS	VSS
BZ Freq.	BZSEL1	BZSEL2																
8.0KHz	VDD or Open	VDD or Open																
6.4KHz	VSS	VDD or Open																
5.3KHz	VDD or Open	VSS																
4.0KHz	VSS	VSS																
26 27	STSEL1 STSEL2	I I	Pull-High Input Pad , Bonding-Option for Stable Time : <table border="1" style="margin-left: 20px;"> <thead> <tr> <th>Stable Time</th> <th>STSEL1</th> <th>STSEL2</th> </tr> </thead> <tbody> <tr> <td>16 Sec</td> <td>VDD or Open</td> <td>VDD or Open</td> </tr> <tr> <td>4 Sec</td> <td>VSS</td> <td>VDD or Open</td> </tr> <tr> <td>8 Sec</td> <td>VDD or Open</td> <td>VSS</td> </tr> <tr> <td>32 Sec</td> <td>VSS</td> <td>VSS</td> </tr> </tbody> </table>	Stable Time	STSEL1	STSEL2	16 Sec	VDD or Open	VDD or Open	4 Sec	VSS	VDD or Open	8 Sec	VDD or Open	VSS	32 Sec	VSS	VSS
Stable Time	STSEL1	STSEL2																
16 Sec	VDD or Open	VDD or Open																
4 Sec	VSS	VDD or Open																
8 Sec	VDD or Open	VSS																
32 Sec	VSS	VSS																
28	OSCI	I	System Oscillator Input Pad															
29	OSCO	O	System Oscillator Output Pad															
30	BZ1	O	Buzzer Output Pad-1															
31	BZ2	O	Buzzer Output Pad-2															
32~34	COM1~COM3	O	LCD Common Driver , Connect to LCD															

• **Electrical Parameter :**

Description		Max.	Typical	Min.
1. Operating Voltage :		1.65V	1.50V	1.20V
2. Operating Average Current :		50uA	30uA	
3. Input Voltage :	VIL	Vss+0.3V		
	VIH			Vdd-0.3V
4. Output Voltage :	VOL	Vss+0.1V		
	VOH			Vdd-0.1V
5. Buzzer Driving Current : (Vds=1/2 Vdd)				1mA
6. Buzzer Sinking Current : (Vds=1/2 Vdd)				1mA
7. Pull-high Resistor : PSW Pad			1MΩ	
8. Pull-high Resistor : SFC 、CHCF 、 BZSEL1 、BZSEL2 、STSEL1 、STSEL2 Pad			500KΩ	
9. Pull-high Resistor : TEST1 、TEST2 Pad			60KΩ	

• Function Description :

- <1> Power SW : Push PSW switch to Power-ON or Power-OFF.
- <2> When Power-ON : Push the switch , a “ BI ” Sound for 0.125 Sec will be generated.
 - A. The LCD display (188.8°M for **B-1** ; 188.8°C or 188.8°F for **B-2**) about **2 Sec**.
 - B. After A :
 - B-1. When CHCF=VDD or Open($^{\circ}\text{C}/^{\circ}\text{F}$ is not Changeable Mode by Pushing switch)**
The LCD Displays the Last Measuring Temperature and “ M ” Mark about **2 Sec** then Jump to the Step-C.
 - B-2. When CHCF=VSS($^{\circ}\text{C}/^{\circ}\text{F}$ is Changeable Mode by Pushing switch)**
If Push-Switch Over **2 Sec** , the $^{\circ}\text{C}/^{\circ}\text{F}$ mode will be changed to another mode and only Display $^{\circ}\text{C}$ (or $^{\circ}\text{F}$) until Release-Switch. And then the LCD displays the Lo $^{\circ}\text{C}$ (or Lo $^{\circ}\text{F}$) and “ M ” Mark about **2 Sec** then Jump to the Step-C.
 - C. After B :
LCD Displays the Self-Test Temperature (**Normal $37.0^{\circ}\text{C} / 98.6^{\circ}\text{F}$**) about **1 Sec**.
The $^{\circ}\text{C}/^{\circ}\text{F}$ Mark will start to Flash at the speed of **1Hz**
and Starts to Count the Stable-Time.
 - D. After C :
It will Start to Measure Temperature and the $^{\circ}\text{C}/^{\circ}\text{F}$ mark Flash at the speed of **1Hz**.
The LCD always Displays the Highest Measuring Temperature.
 - E. If the Temperature $< 32.0^{\circ}\text{C}$ (or 90.0°F) : the LCD Displays Lo $^{\circ}\text{C}$ (or Lo $^{\circ}\text{F}$).
 - F. If the Temperature $\geq 43.0^{\circ}\text{C}$ (or 110.0°F) : the LCD Displays Hi $^{\circ}\text{C}$ (or Hi $^{\circ}\text{F}$).
 - G. When Measuring : the LCD will always Display the Highest Temperature.
 - H. If the Measure Temperature does not Change within the Stable-Time ,
the Measurement will be Over and the $^{\circ}\text{C}$ ($^{\circ}\text{F}$) Mark Flash-Stop.
 - I. When Measurement is Over and if the temperature $\geq 37.8^{\circ}\text{C}$ (100.0°F) ,
the Buzzer will Alarm “ BI—BI—BI——BI—BI—BI—— ” for 10 Sec , as follows :
BI—BI—BI——BI—
BI : 0.125 Sec
— : 0.125 Sec
—— : 0.375 Sec
If the temperature $< 37.8^{\circ}\text{C}$ (100.0°F) ,
the Buzzer will Alarms “ BI—BI—BI—BI— ” for 10 Sec , as follows :
BI—BI—
BI : 0.5 Sec
— : 0.5 Sec
 - J. It will Automatically Power-OFF after measurement is Stable and the system is still on more than 8 min 40 sec($F_{\text{sys}}=32768\text{Hz}$).
 - K. When Measurement is Over and the Beep-Sound is terminated ,
if the Temperature Rises within 8 min 40 sec , the Measurement will start again ,
but the $^{\circ}\text{C}$ ($^{\circ}\text{F}$) mark will Not Flash and the Buzzer will **Not Output** also.
 - L. During BI-Sound is on 10 Sec and Delay 2 sec , the Temperature is not Measurement.

- <3> When Power-OFF : the Stand-By Current $\leq 1\mu\text{A}$.
- <4> Measurement to 0.1 degree at $^{\circ}\text{C}$ or $^{\circ}\text{F}$.
- <5> Sensor use **503ET**.
- <6> Reference Resistor is the Value Sensor in **37.0 $^{\circ}\text{C}$** .
- <7> When Battery Voltage is Low , the battery mark "■" will Flash at the speed of **1Hz**.
And the Measurement maybe not Accurate , it means thermometer must be changed Battery.
The Low Voltage Detect : (**TCP310A : $1.30 \pm 0.05\text{V}$** ; **TCP310B : $1.25 \pm 0.05\text{V}$**).
- <8> When TEST2-Pin is connected to VSS :
the LCD will Display the Real-Time Value not the highest value ,
in order to Adjust the reference resistance R_F during the process of producing.
The LCD can be up or down changed , not always Display the Highest Value.
- <9> When Sensor circuit detect Error :
LCD only Display " Err " , it will not measure normally until the Error status Cancel.
- <10> The Frequency of Buzzer is selected By BZSEL1 and BZSEL2 Pads-Option.

Buzzer frequency	BZSEL1	BZSEL2
8.0 KHz	VDD or Open	VDD or Open
6.4 KHz	VSS	VDD or Open
5.3 KHz	VDD or Open	VSS
4.0 KHz	VSS	VSS

- <11> The 4 Kinds of Stable-Time are 4 Sec / 8 Sec / 16 Sec and 32 Sec to be selected by STSEL1 and STSEL2 Pads-Option.

Stable Time	STSEL1	STSEL2
16 Sec	VDD or Open	VDD or Open
4 Sec	VSS	VDD or Open
8 Sec	VDD or Open	VSS
32 Sec	VSS	VSS

- <12> $^{\circ}\text{C}/^{\circ}\text{F}$ Power-ON Initial Function is used SFC Pad-Option.

Mode	SFC
$^{\circ}\text{C}$	VDD or Open
$^{\circ}\text{F}$	VSS

- <13> $^{\circ}\text{C}/^{\circ}\text{F}$ Changeable or Not-Changeable Mode is used CHCF Pad-Option.

	CHCF
Not Changeable Mode	VDD or Open
Changeable Mode	VSS

Note : At Changeable Mode(CHCF=VSS) , Power ON Initial(**by Battery**) :
Maybe the LCD Display($^{\circ}\text{C}$ or $^{\circ}\text{F}$) will be Fail , it must be **Re-Power ON** Initial.

- <14> Thermometer others character is below:

Temperature range	32.0 $^{\circ}\text{C}$ ~ 42.9 $^{\circ}\text{C}$	90.0 $^{\circ}\text{F}$ ~ 109.9 $^{\circ}\text{F}$
Accuracy	± 0.1 $^{\circ}\text{C}$	± 0.2 $^{\circ}\text{F}$
Resolution	0.1 $^{\circ}\text{C}$	0.1 $^{\circ}\text{F}$

• LCD Pattern :

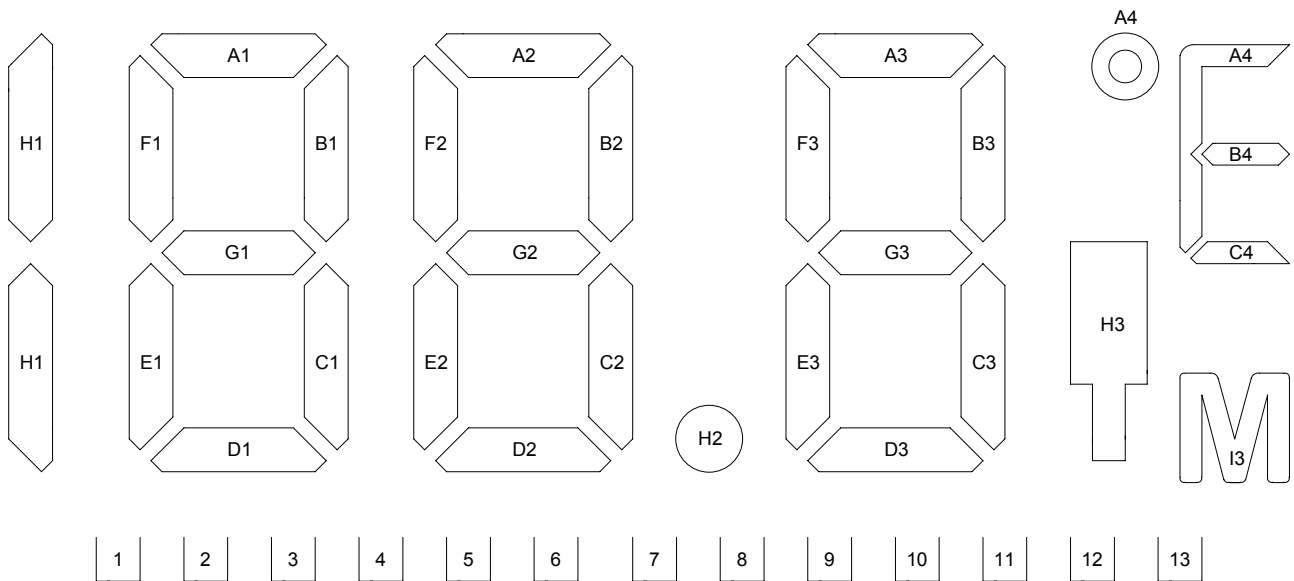

TCP310 Pin Name	COM1	COM2	COM3	S1	S2	S3	S4	S5	S6	S7	S8	S9	S10
	1	2	3	4	5	6	7	8	9	10	11	12	13
COM1	COM1			F1	A1	B1	F2	A2	B2	F3	A3	B3	A4
COM2		COM2		E1	G1	C1	E2	G2	C2	E3	G3	C3	B4
COM3			COM3	H1	D1			D2	H2	I 3	D3	H3	C4

SPEC : A . 1/3 DUTY , 1/2 BIAS . (LCD USES 3 V)
 B . $V_{TH} = 1.5 V$

• Application Circuit :

TCP310A/TCP310B Application Circuit

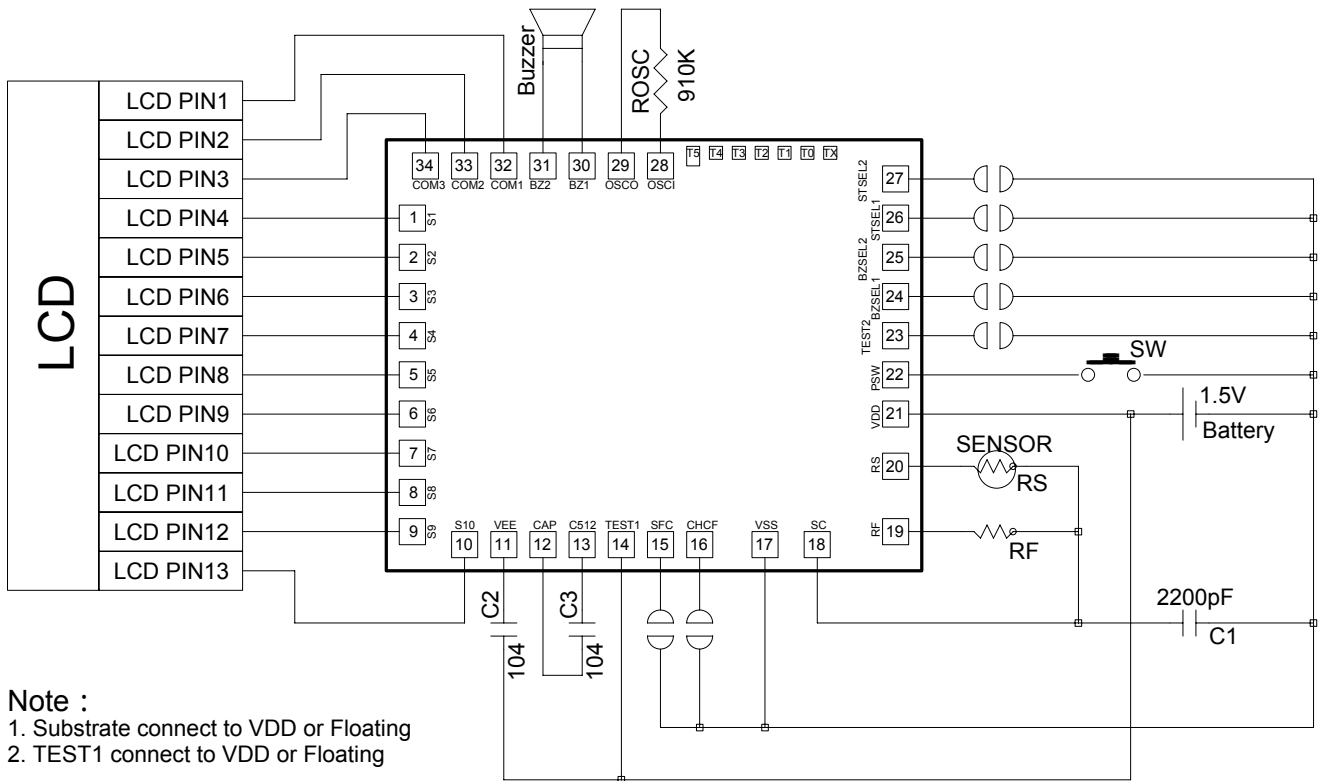

Note :

1. Substrate connect to VDD or Floating
2. TEST1 connect to VDD or Floating

Remark :

1. Sensor use **503ET** sensor.
2. RF is selected according to sensor type , RF resistor is the value of sensor **503ET** in **37.0°C**.
3. About the PCB layout , recommends to do according to following methods.
 - 3-1. The **ROsc** device should be located near the TCP310A/TCP310B IC's **OSCI** and **OSCO** pins.
 - 3-2. The lines of SC 、RF 、RS do not parallel and near with the lines of OSCI 、OSCO.

The space between lines of SC 、RF 、RS and other lines must be large as far as.

4. Option table :

SFC PAD	°C/°F MODE
VDD or Open	°C Mode
VSS	°F Mode
CHCF PAD	°C/°F MODE
VDD or Open	Not Changeable Mode
VSS	Changeable Mode

Note : At Changeable Mode(CHCF=VSS) , Power ON Initial(**by Battery**) :
 Maybe the LCD Display(°C or °F) will be Fail , it must be **Re-Power ON** Initial.

BZSEL1 PAD	BZSEL2 PAD	Buzzer Frequency
VDD or Open	VDD or Open	8.0KHz
VSS	VDD or Open	6.4KHz
VDD or Open	VSS	5.3KHz
VSS	VSS	4.0KHz

STSEL1 PAD	STSEL2 PAD	Stable Time
VDD or Open	VDD or Open	16sec
VSS	VDD or Open	4sec
VDD or Open	VSS	8sec
VSS	VSS	32sec

• PAD Location :

TCP310A/TCP310B PAD'S Diagram

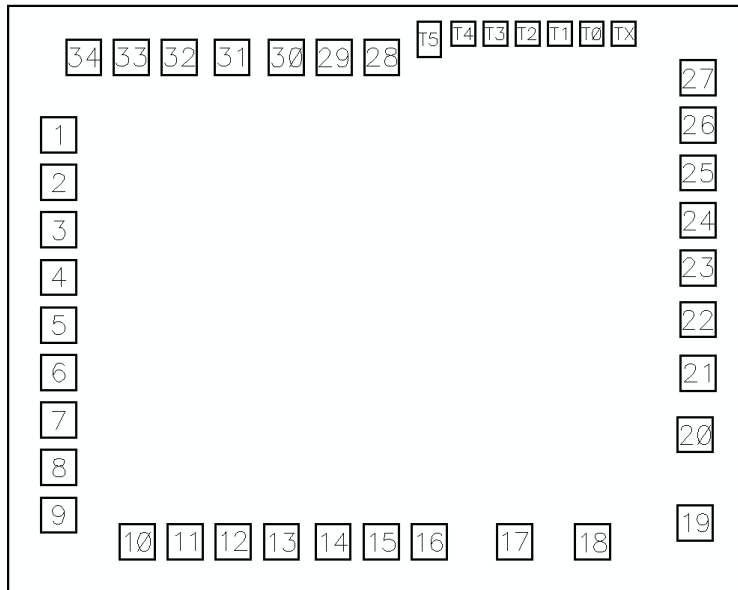

TCP310 Chip Size = 1880um x 1500um
Substrate **Floating**(recommend) or **VDD**

Pad's Coordinate :

Pad No.	Pad Name	X	Y	Pad No.	Pad Name	X	Y
1	S1	-776.600	398.600	18	SC	520.250	-586.600
2	S2	-776.600	283.600	19	RF	770.400	-540.600
3	S3	-776.600	168.600	20	RS	770.400	-326.400
4	S4	-776.600	53.600	21	VDD	776.600	-178.900
5	S5	-776.600	-61.400	22	PSW	776.600	-48.300
6	S6	-776.600	-176.400	23	TEST2	776.600	76.800
7	S7	-776.600	-291.400	24	BZSEL1	776.600	191.800
8	S8	-776.600	-406.400	25	BZSEL2	776.600	306.800
9	S9	-776.600	-521.400	26	STSEL1	776.600	421.800
10	S10	-586.600	-586.600	27	STSEL2	776.600	536.800
11	VEE	-469.600	-586.600	28	OSCI	8.300	586.600
12	CAP	-352.600	-586.600	29	OSCO	-107.700	586.600
13	C512	-235.600	-586.600	30	BZ1	-223.700	586.600
14	TEST1	-110.200	-586.600	31	BZ2	-356.000	586.600
15	SFC	6.800	-586.600	32	COM1	-484.000	586.600
16	CHCF	123.800	-586.600	33	COM2	-600.000	586.600
17	VSS	330.900	-586.600	34	COM3	-716.000	586.600

Note : Pad Window Size = 85um x 85um

Pad No.	Pad Name	X	Y
TX	TRIMVDD	596.700	642.900
T0	TRIM0	518.700	642.900
T1	TRIM1	440.700	642.900
T2	TRIM2	362.700	642.900
T3	TRIM3	284.700	642.900
T4	TRIM4	206.700	642.900
T5	TRIM5	123.700	629.700

Note : Trim-Pad Window Size = 58um x 58um

• Function Flow Chart :

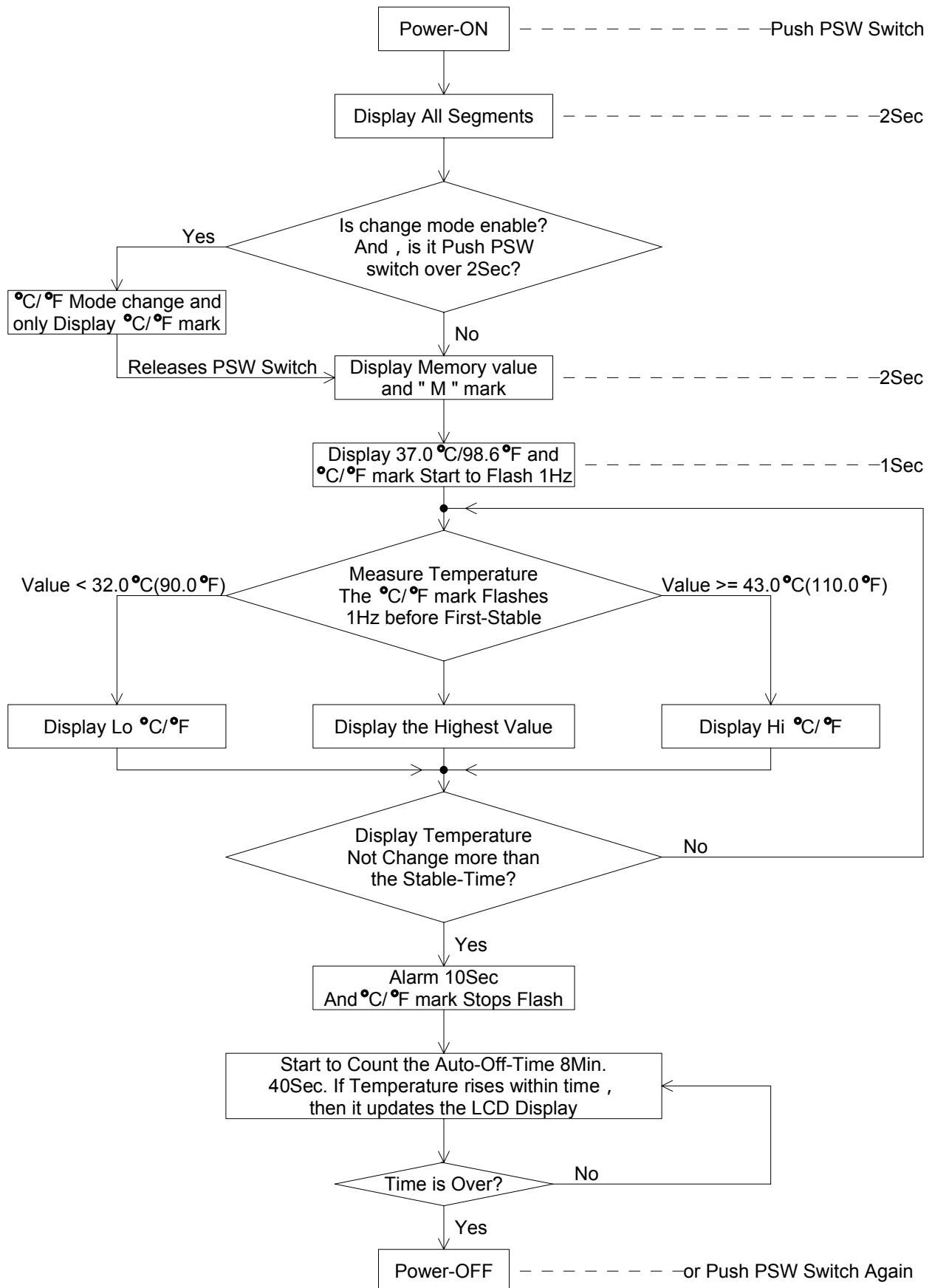

• Order Information :

1. For TCP310A :
 - a. Package form : **No support**
 - b. Chip form : TCP310A
 - c. Wafer base : TDP310A
2. For TCP310B :
 - a. Package form : **No support**
 - b. Chip form : TCP310B
 - c. Wafer base : TDP310B

• Revise History :

1. 2014/06/30
-Original version : Ver 1.0