

THERMOMETER SPECIFICATION

Contents :

- General Description :3
- Features :3
- Block Diagram :4
- Pad Description :5
- Electrical Parameter :6
- Function Description :7
-8
- LCD Pattern :9
- Application Circuit :10
- PAD Location :11
- Function Flow Chart :12
- Order Information :13
- Revise History :13

• General Description :

The TCP313 is an **one-decimal or two-decimal** electronic clinical thermometer IC.

• Features :

- ✧ Single 1.5V Battery Power-Supply
- ✧ Automatic Power-OFF Function
- ✧ Built-in Low-Voltage Detector Function
[LVD == 1.30 ± 0.05V]
- ✧ Measurement Range : **32.0°C ~ 42.9°C (89.6°F ~ 109.3°F)** or
32.00°C ~ 42.99°C (89.60°F ~ 109.39°F)
- ✧ Measurement Accuracy : ± 0.1°C (± 0.2°F)
- ✧ Resolution : **0.1°C (0.1°F)** or **0.01°C (0.01°F)**
- ✧ Highest Temperature Hold
- ✧ **Fever-Alarm Function** : Temperature ≥ **37.50 °C (99.50 °F)**
- ✧ **Memory Function** : Display the Last Measuring Temperature.
- ✧ Bonding-Option for LCD display after the decimal point **One** or **Two digits**
[Default **Two digits**]
- ✧ Bonding-Option for Stable Time Selection : **4 sec / 8 sec / 16 sec / 32 sec**
[Default **16 sec**]
- ✧ Bonding-Option for Buzzer Alarm Frequency : **5.3 KHz / 6.4 KHz**
[Default **5.3 KHz**]
- ✧ Bonding-Option for °C or °F
[Default °C]

• Block Diagram :

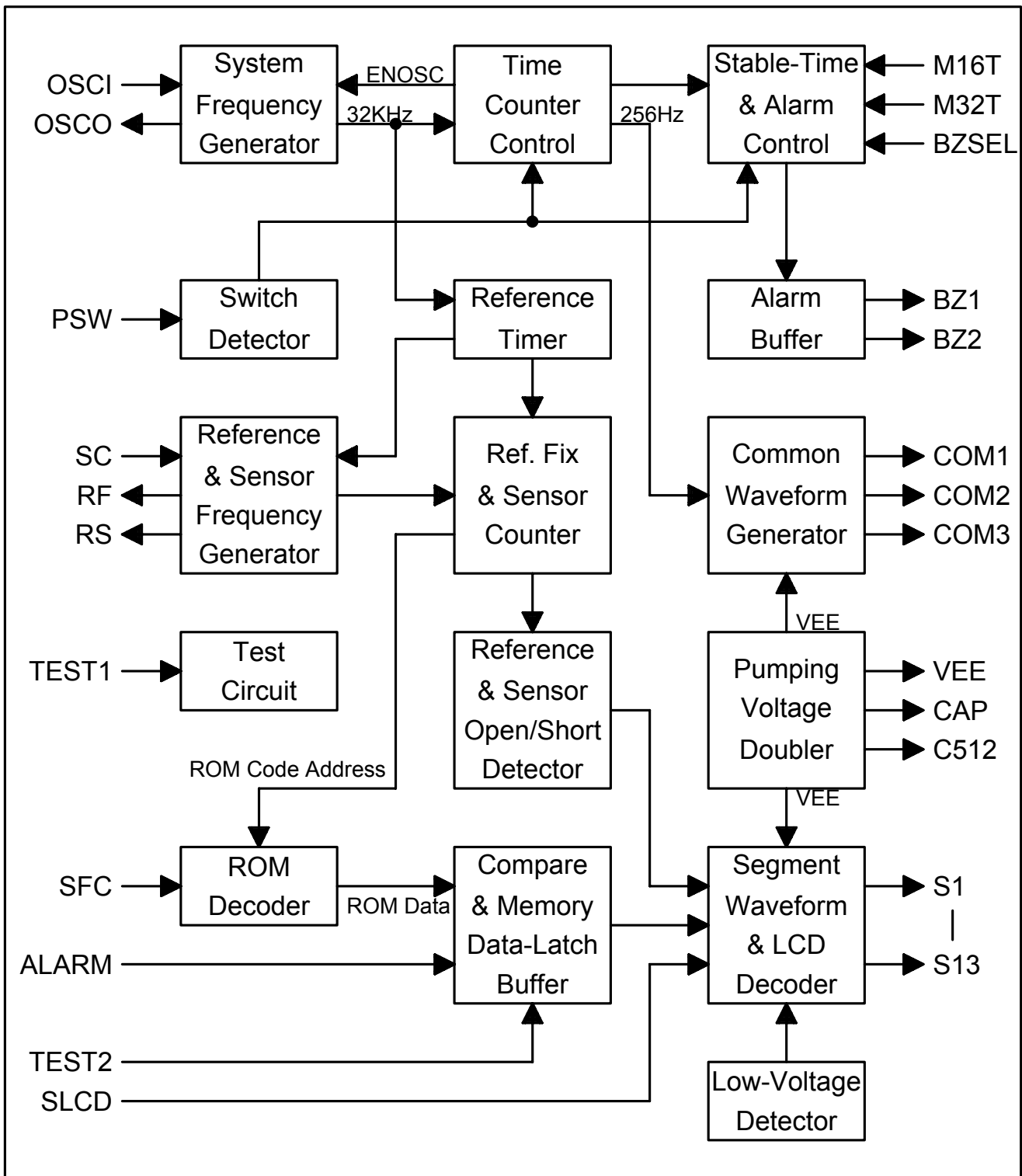

• Pad Description :

Pad No.	Pad Name	I/O	Description															
1	VSS	P	Negative Power-Supply															
2	SC	I	Reference and Sensor Frequency Input															
3	RF	O	Connect to Reference Resistor															
4	RS	O	Connect to Sensor Resistor															
5	BZ1	O	Buzzer Output Pad-1															
6	BZ2	O	Buzzer Output Pad-2															
7~9	COM1~COM3	O	LCD Common Driver , Connect to LCD															
10~22	S1~S13	O	LCD Segment Driver , Connect to LCD															
23	C512	O	For Double Voltage Pumping															
24	CAP	O	For Double Voltage Pumping															
25	VDD	P	Positive Power-Supply															
26	VEE	O	Generated 3.0V Voltage(VDD=1.5V)															
27	PSW	I	Pull-High Input Pad , Push-Switch to Power-ON or Power-OFF															
28	OSCO	O	System Oscillator Output Pad															
29	OSCI	I	System Oscillator Input Pad															
30	TEST1	I	Pull-Low Input Test-Pad , For IC Test Only															
31	BZSEL	I	Pull-High Input Pad , Bonding-Option for Buzzer Output Frequency : <table border="1" data-bbox="587 936 1053 1037"> <thead> <tr> <th>BZ Freq.</th> <th>BZSEL</th> </tr> </thead> <tbody> <tr> <td>5.3KHz</td> <td>VDD or Open</td> </tr> <tr> <td>6.4KHz</td> <td>VSS</td> </tr> </tbody> </table>	BZ Freq.	BZSEL	5.3KHz	VDD or Open	6.4KHz	VSS									
BZ Freq.	BZSEL																	
5.3KHz	VDD or Open																	
6.4KHz	VSS																	
32	TEST2	I	Pull-High Input Pad , for the Test of Production TEST2= VDD or Open : LCD Display the Highest Value TEST2= VSS : LCD Display the Real-Time Value															
33	SLCD	I	Pull-High Input Pad , Bonding-Option for Select LCD Display : <table border="1" data-bbox="587 1227 1318 1328"> <thead> <tr> <th>Display</th> <th>After Decimal point</th> <th>SLCD</th> </tr> </thead> <tbody> <tr> <td>188.88</td> <td>Two digits</td> <td>VDD or Open</td> </tr> <tr> <td>188.8</td> <td>One digit</td> <td>VSS</td> </tr> </tbody> </table>	Display	After Decimal point	SLCD	188.88	Two digits	VDD or Open	188.8	One digit	VSS						
Display	After Decimal point	SLCD																
188.88	Two digits	VDD or Open																
188.8	One digit	VSS																
34	SFC	I	Pull-High Input Pad , Bonding-Option for Select °C or °F Mode : <table border="1" data-bbox="587 1413 1053 1514"> <thead> <tr> <th>C / F</th> <th>SFC</th> </tr> </thead> <tbody> <tr> <td>°C</td> <td>VDD or Open</td> </tr> <tr> <td>°F</td> <td>VSS</td> </tr> </tbody> </table>	C / F	SFC	°C	VDD or Open	°F	VSS									
C / F	SFC																	
°C	VDD or Open																	
°F	VSS																	
35	ALARM	I	Pull-High Input Pad , Bonding-Option for Select Fever-Alarm : <table border="1" data-bbox="587 1592 1053 1693"> <thead> <tr> <th>Alarm</th> <th>ALARM</th> </tr> </thead> <tbody> <tr> <td>Fever</td> <td>VDD or Open</td> </tr> <tr> <td>No-Fever</td> <td>VSS</td> </tr> </tbody> </table>	Alarm	ALARM	Fever	VDD or Open	No-Fever	VSS									
Alarm	ALARM																	
Fever	VDD or Open																	
No-Fever	VSS																	
36 37	M16T M32T	I I	Pull-High Input Pad , Bonding-Option for Stable Time : <table border="1" data-bbox="587 1765 1318 1924"> <thead> <tr> <th>Stable Time</th> <th>M16T</th> <th>M32T</th> </tr> </thead> <tbody> <tr> <td>16 Sec</td> <td>VDD or Open</td> <td>VDD or Open</td> </tr> <tr> <td>8 Sec</td> <td>VSS</td> <td>VDD or Open</td> </tr> <tr> <td>32 Sec</td> <td>VDD or Open</td> <td>VSS</td> </tr> <tr> <td>4 Sec</td> <td>VSS</td> <td>VSS</td> </tr> </tbody> </table>	Stable Time	M16T	M32T	16 Sec	VDD or Open	VDD or Open	8 Sec	VSS	VDD or Open	32 Sec	VDD or Open	VSS	4 Sec	VSS	VSS
Stable Time	M16T	M32T																
16 Sec	VDD or Open	VDD or Open																
8 Sec	VSS	VDD or Open																
32 Sec	VDD or Open	VSS																
4 Sec	VSS	VSS																

• Electrical Parameter :

Description		Max.	Typical	Min.
1. Operating Voltage :		1.6V	1.5V	1.3V
2. Operating Average Current :		30uA		
3. Input Voltage :	VIL	Vss+0.3V		
	VIH			Vdd-0.3V
4. Output Voltage :	VOL	Vss+0.1V		
	VOH			Vdd-0.1V
5. Buzzer Driving Current : (Vds=1/2 Vdd)				1mA
6. Buzzer Sinking Current : (Vds=1/2 Vdd)				1mA
7. Pull-High Resistor : PSW Pad			500KΩ	
8. Pull-High Resistor : TEST2 Pad			10KΩ	
9. Pull-Low Resistor : TEST1 Pad			25KΩ	

• Function Description :

- <1> Power SW : Push Switch can **Turn-ON** or **Turn-OFF** the thermometer
- <2> At Power-ON :
- A. LCD display 100.00°C (or 100.00°F) **2 sec** at first
 - B. Following A : If Push Switch more than **2 sec** , LCD will display the stable-temperature of last measured until release switch and memory mark "**M**" also display
 - C. Following B : Display 36.50°C (or 97.70°F) **1 sec** ,
if sensor circuit is detected abnormal status , LCD will only display "**Err**"
 - D. When measuring , the mark $^{\circ}\text{C}$ (or $^{\circ}\text{F}$) **Flash** by **1Hz** until temperature is stabilization
 - E. After Push Switch or Memory display finish , there are 8 sec to be ignore for counter of stable-temperature time
 - F. If measuring temperature $< 32.00^{\circ}\text{C}$ (89.60°F) , LCD display **Lo** $^{\circ}\text{C}$ ($^{\circ}\text{F}$)
 - G. If measuring temperature $\geq 43.00^{\circ}\text{C}$ (109.40°F) , LCD display **Hi** $^{\circ}\text{C}$ ($^{\circ}\text{F}$)
 - H. When measuring , the LCD will always display the **Highest** temperature
 - I. If the measuring temperature is no changed more than **16 sec** (or 8 sec / 32 sec / 4 sec) ,
It means stable-temperature is over and $^{\circ}\text{C}$ ($^{\circ}\text{F}$) mark flash stop
 - J. Four Stable-temperature time 4 sec / 8 sec / 16 sec / 32 sec are selected by **Pad-Option** [Default time is **16 sec**]
 - K. When measuring over and Fever Alarm **Enable** , if temperature $\geq 37.50^{\circ}\text{C}$ (99.50°F) ,
Then Buzzer alarm " Bi-Bi-Bi--- Bi-Bi-Bi--- " about **4 sec** as below :
Bi-----Bi-----Bi-----
0.0625S/0.0625S/0.0625S/0.0625S/0.0625S/0.1875S [Period Cycle = **0.5 sec**]
If temperature $< 37.50^{\circ}\text{C}$ (99.50°F) or Fever Alarm **Disable** ,
then Buzzer also alarm " Bi- " about **4 sec** as below :
Bi-
0.5S/ 0.5S [Period Cycle = **1 sec**]
 - L. Fever alarm is selected by **Pad-Option** [Default : Fever Alarm **Enable**]
 - M. It will **Auto Power-OFF** when the Stable-Temperature measurement is over than **10 Minutes**
The 10 minutes is constant , it is not recount by the temperature raising again
 - N. When measurement is over within 10 minutes , if temperature rises again the $^{\circ}\text{C}$ ($^{\circ}\text{F}$) mark **No-Blink** and remeasure the temperature , but the buzzer will not alarm again when measurement is over and 10 minutes is not recount
The LCD will display the new value of measuring
- <3> After(2-B) : If detect **Low-Voltage** , LCD only display battery mark " **■** " ,
means thermometer must be changed battery
[**LVD == 1.30 ± 0.05V**]
- <4> When **Reference/Sensor** Resistor is Open or Short , LCD only display " **Err** "
until Reference/Sensor Resistor **Recover Normal**
- <5> When Push switch , the Buzzer will alarm " Bi " about **0.078 sec**
- <6> The Stand-By current $\leq 0.5 \mu\text{A}$ at Power-OFF status
- <7> Two **Frequency** of Buzzer **5.3 KHz** / **6.4 KHz** are selected by **Pad-Option**
[Default Frequency is **5.3 KHz**]
- <8> When LCD display " **Lo** " , if temperature rise and stable-temperature time will count again with following item (2-I) description

- <9> Test2 Pin connect to **VSS** , LCD display is **Real-Time** temperature ,
not the Highest temperature in order to adjust **Reference** Resistor
- <10> °C or °F be selected by Pad option [Default is °C]
- <11> LCD display which is One number after point or Two numbers after point is selected by **Pad-Option** [Default is **Two numbers** after point LCD display]
- <12> Sampling Period **2 sec**
- <13> Thermometer others character is below :

A. Two numbers after point :

Temperature range	32.00°C ~ 42.99°C	89.60°F ~ 109.39°F
Accuracy	± 0.1 °C	± 0.2 °F.
Resolution	0.01 °C	0.01 °F

B. One number after point :

Temperature range	32.0°C ~ 42.9°C	89.6°F ~ 109.3°F
Accuracy	± 0.1 °C	± 0.2 °F.
Resolution	0.1 °C	0.1 °F

<14> Pad-Option Table :

Pad name	Default [VDD or Open]	Connect to VSS
TEST2	Highest Temperature	Real Temperature
SLCD	Two numbers after point	One number after point
SFC	°C	°F
ALARM	Fever Alarm	No-Fever Alarm
BZSEL	5.3 KHz	6.4 KHz

The 4 Kinds of Stable-Time are 4 sec / 8 sec / 16 sec / 32 sec
to be selected by M16T and M32T Pads-Option [Default time is **16 sec**]

Stable Time	M16T	M32T
16 sec	VDD or Open	VDD or Open
8 sec	VSS	VDD or Open
32 sec	VDD or Open	VSS
4 sec	VSS	VSS

• LCD Pattern :

1	2	3	4	5	6	7	8	9	10	11	12	13	14	15	16	
IC_PIN	COM1	COM2	COM3	S1	S2	S3	S4	S5	S6	S7	S8	S9	S10	S11	S12	S13
LCD_PIN	1	2	3	4	5	6	7	8	9	10	11	12	13	14	15	16
COM1	COM1			F1	A1	B1	F2	A2	B2	F3	A3	B3	F4	A4	B4	A5
COM2		COM2		E1	G1	C1	E2	G2	C2	E3	G3	C3	E4	G4	C4	B5
COM3			COM3	H1	D1			D2	H2		D3		I4	D4	H4	C5

SPEC : A . 1/3 DUTY , 1/2 BIAS . (LCD USES 3 V)
 B . $V_{TH} = 1.5 V$

1	2	3	4	5	6	7	8	9	10	11	12	13	
IC_PIN	COM1	COM2	COM3	S1	S2	S3	S4	S5	S6	S7	S8	S9	S13
LCD_PIN	1	2	3	4	5	6	7	8	9	10	11	12	13
COM1	COM1			F1	A1	B1	F2	A2	B2	F3	A3	B3	A4
COM2		COM2		E1	G1	C1	E2	G2	C2	E3	G3	C3	B4
COM3			COM3	H1	D1			D2	H2	I3	D3	H3	C4

SPEC : A . 1/3 DUTY , 1/2 BIAS . (LCD USES 3 V)
 B . $V_{TH} = 1.5 V$

• Application Circuit :

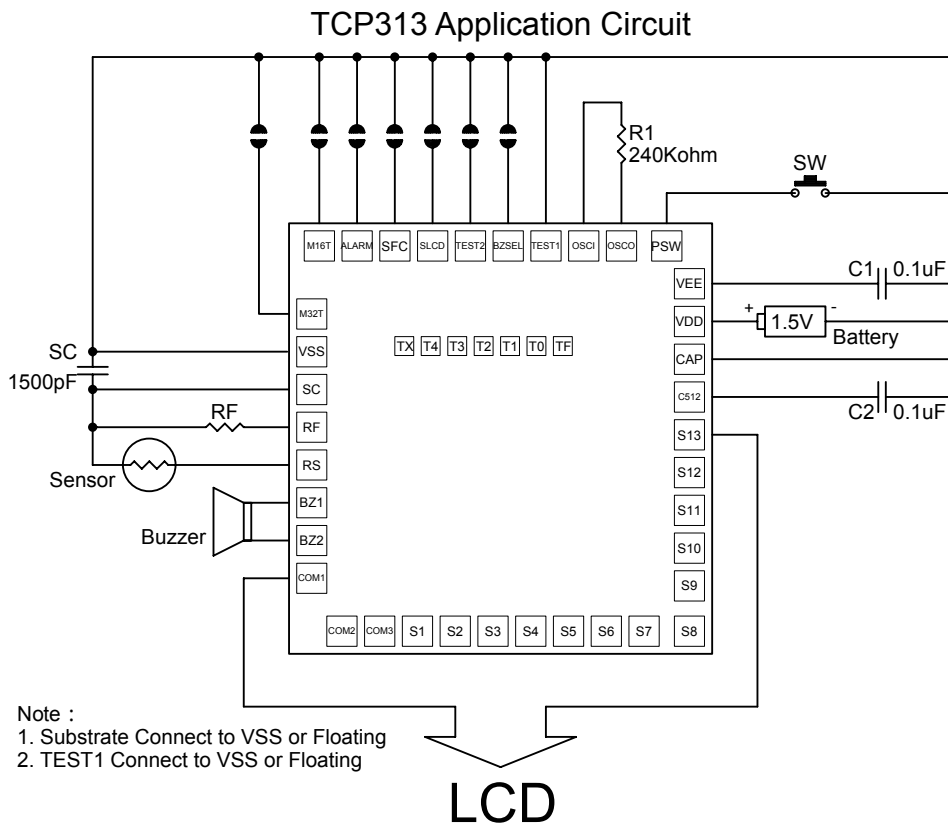

Remark :

1. Sensor use **503ET** sensor.
2. RF is selected according to sensor type , RF resistor is the value of sensor **503ET** in **37.0°C**.
3. About the PCB layout , recommends to do according to following methods.
 - 3-1. The **ROSC** device should be located near the TCP313 IC's **OSCI** and **OSCO** pins.
 - 3-2. The lines of SC 、 RF 、 RS do not parallel and near with the lines of OSCI 、 OSCO.

The space between lines of SC 、 RF 、 RS and other lines must be large as far as.

4. Option Table :

Pad name	Default [VDD or Open]	Connect to VSS
TEST2	Highest Temperature	Real Temperature
SLCD	Two numbers after point	One number after point
SFC	°C	°F
ALARM	Fever Alarm	No-Fever Alarm
BZSEL	5.3 KHz	6.4 KHz

Stable Time	M16T	M32T
16 sec	VDD or Open	VDD or Open
8 sec	VSS	VDD or Open
32 sec	VDD or Open	VSS
4 sec	VSS	VSS

[Default time is 16 sec]

• PAD Location :

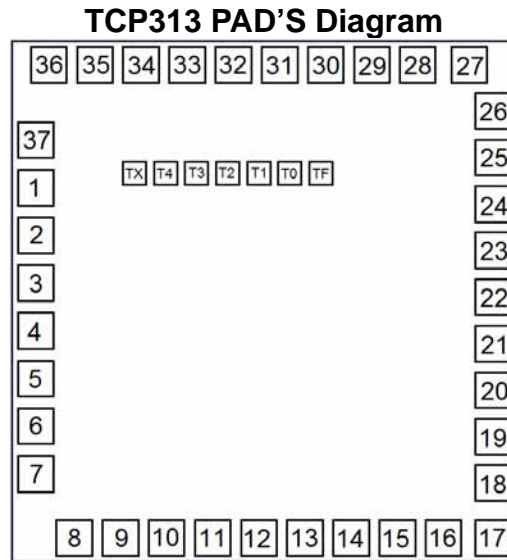

TCP313 Chip Size = 1350um x 1390um

Substrate **Floating**(recommend) or **VSS**

Pad's Coordinate :

Pad No.	Pad Name	X	Y	Pad No.	Pad Name	X	Y
1	VSS	-575.000	286.000	20	S11	575.000	-223.000
2	SC	-575.000	166.000	21	S12	575.000	-106.000
3	RF	-575.000	46.000	22	S13	575.000	11.000
4	RS	-575.000	-74.000	23	C512	575.000	128.000
5	BZ1	-575.000	-194.000	24	CAP	575.000	245.000
6	BZ2	-575.000	-314.000	25	VDD	575.000	362.000
7	COM1	-575.000	-434.000	26	VEE	575.000	479.000
8	COM2	-478.000	-595.000	27	PSW	515.000	595.000
9	COM3	-362.000	-595.000	28	OSCO	385.000	595.000
10	S1	-246.000	-595.000	29	OSCI	270.000	595.000
11	S2	-130.000	-595.000	30	TEST1	154.000	595.000
12	S3	-14.000	-595.000	31	BZSEL	38.000	595.000
13	S4	102.000	-595.000	32	TEST2	-78.000	595.000
14	S5	218.000	-595.000	33	SLCD	-194.000	595.000
15	S6	334.000	-595.000	34	SFC	-310.000	595.000
16	S7	450.000	-595.000	35	ALARM	-426.000	595.000
17	S8	575.000	-595.000	36	M16T	-542.000	595.000
18	S9	575.000	-457.000	37	M32T	-575.000	406.000
19	S10	575.000	-340.000				

Note : Pad Window Size = **90um x 90um**

Pad No.	Pad Name	X	Y
TF	TRIMF	141.600	322.900
T0	TRIM0	63.600	322.900
T1	TRIM1	-14.400	322.900
T2	TRIM2	-92.400	322.900
T3	TRIM3	-170.400	322.900
T4	TRIM4	-248.400	322.900
TX	TRVSS	-326.400	322.900

Note : Trim-Pad Window Size = **58um x 58um**

• Function Flow Chart :

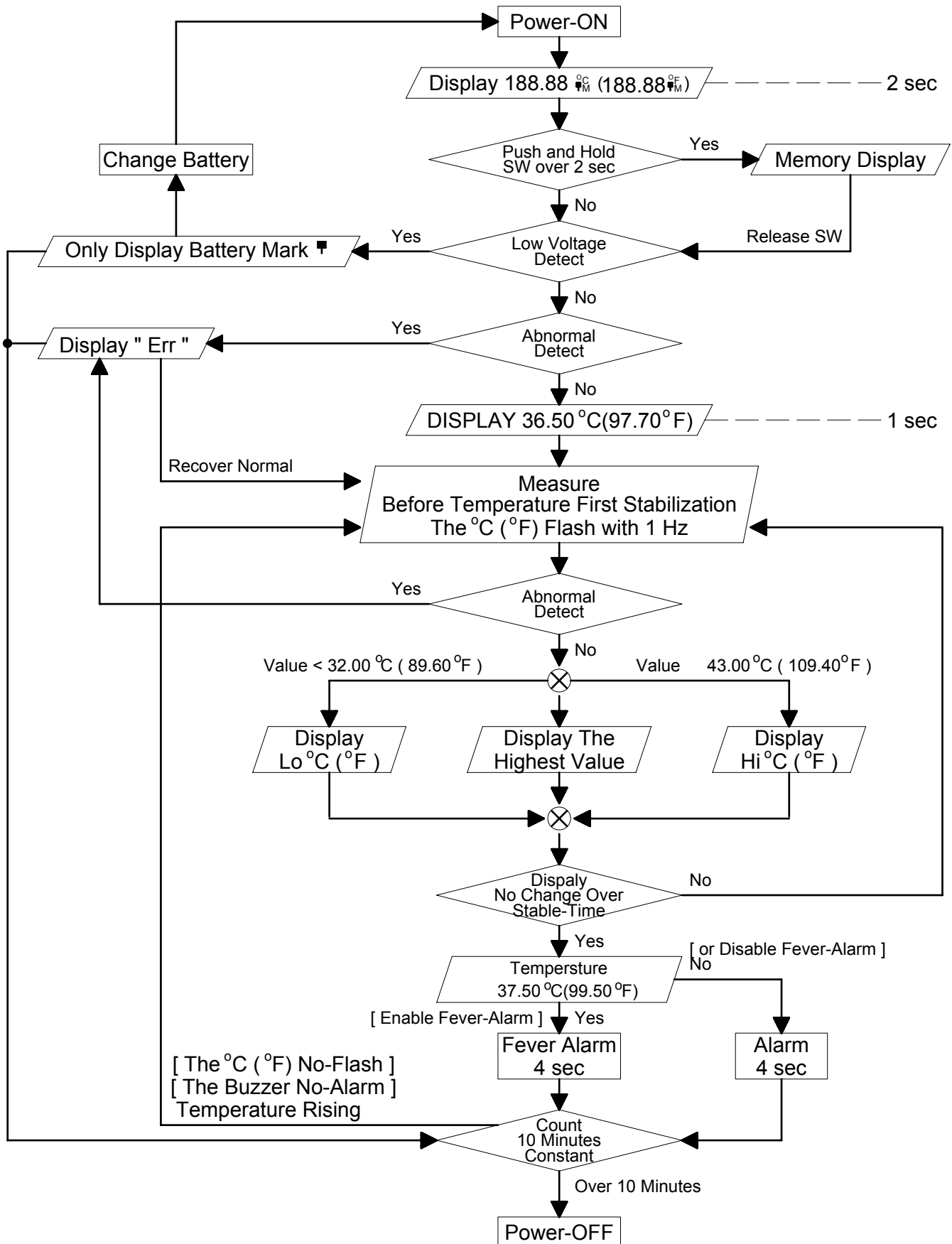

Ordering Information**TCP313**

Package Type	Chip Type	Wafer Type
No support	TCP313	TEP313

• Revise History :

1. 2016/01/06
-Original Version : Ver 1.0