

THERMOMETER SPECIFICATION

CONTENTS:

.General description:.....	3
.Features:	3
.Application:.....	3
.Block diagram:.....	4
.Pad description:.....	5
.Electrical parameter:.....	6
.Function description:.....	7
1 When FSEL=NC: (for TC2156).....	7
2 When FSEL=1: (for TC4367).....	9
.LCD pattern	11
1 LCD connection: (for TC2156, LCD-1).....	11
2 LCD connection: (for TC2156, LCD-2).....	12
3 LCD connection: (for TC4367)	13
.Application circuit.....	15
1 For TC2156 mode.....	15
2 For TC4367 mode.....	16
.PAD location.....	16
.Order information.....	17
.TC8492A and TT5660A/TT5660B function difference explanation	17
.Revise history.....	17

.General description:

The TT5660A/TT5660B is an electronic clinical thermometer IC. It can be push switch to select °C/°F.

.Features:

- ✧ Single 1.5V battery power supply
- ✧ Built-in low voltage detect function
TT5660A: 1.30 ±0.05 V
TT5660B: 1.35 ±0.05 V
- ✧ Provide fever alarm function
- ✧ Automatically turn-off function
- ✧ Buzzer alarm indicates ON/OFF button pushes
- ✧ Buzzer alarm indicates no increase in temperature
- ✧ Buzzer alarm indicates fever detected
- ✧ Within buzzer alarm interval disable peak temperature latch
- ✧ Bonding option read in the biomedical range of 32.0°C to 42.0°C or 32.0°C to 44.0°C
- ✧ Bonding option read in the biomedical range of 89.6°F to 107.6°F or 89.6°F to 111.2°F
- ✧ Bonding option memory function
- ✧ Bonding option °C/°F changeable or not change mode
- ✧ When °C/°F changeable mode, push ON/OFF button to select °C/°F and bonding option °C or °F when power on initial
- ✧ Bonding option buzzer alarm frequency 4K/5.3K/6.4K/8KHz

.Application:

- ✧ 60sec digital LCD thermometer

.Block diagram:

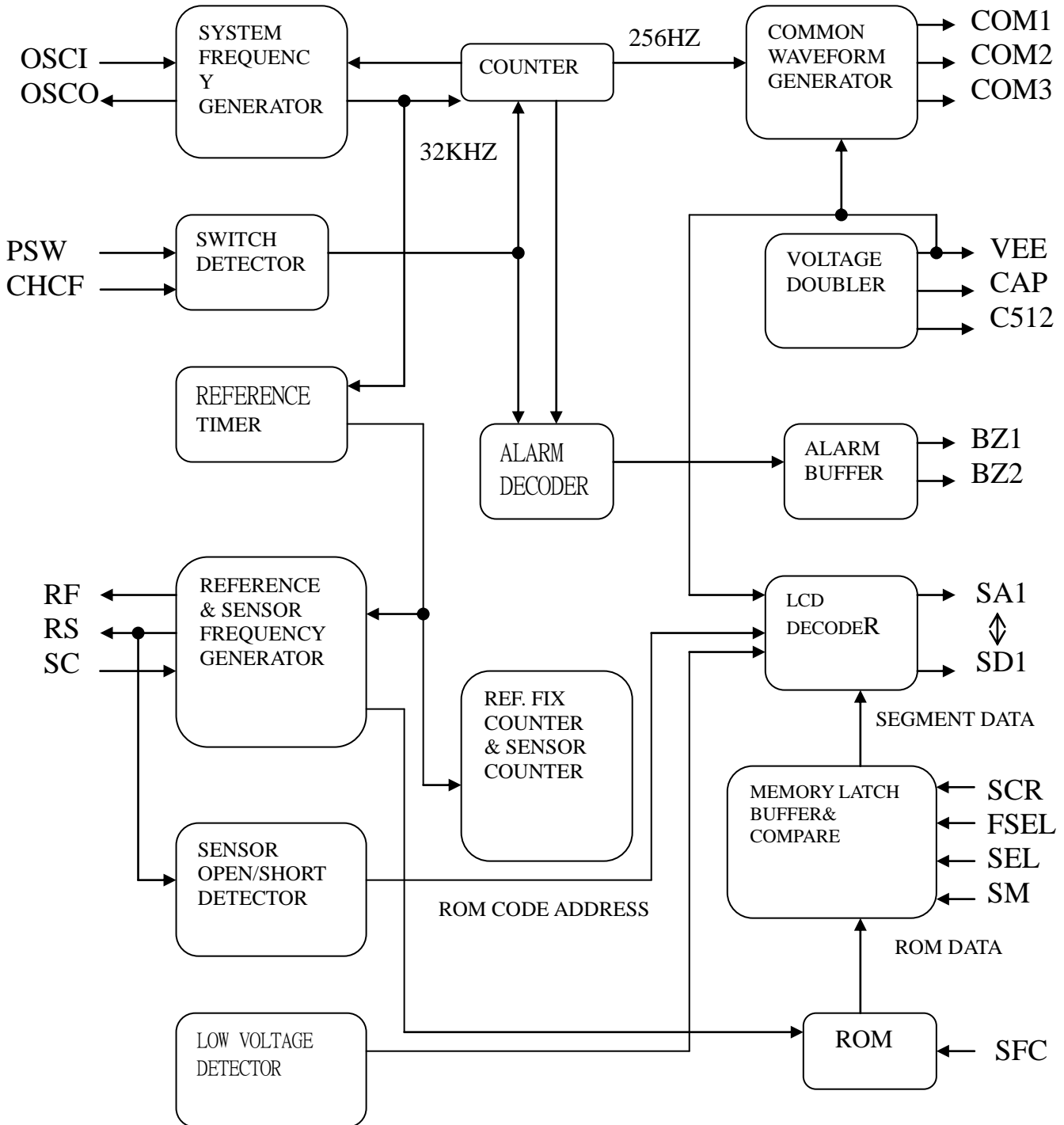

.Pad description:

Pad Name	Description
1 SCR	Buzzer alarm frequency select pad. No connect: 4KHz or 5.3KHz . Connect to VSS: 6.4KHz or 8KHz.
2 SC	Reference and sensor frequency input pad. The reference & sensor frequency generator consists of pad 2, 3, 4.
3 RF	PMOS open drain, connect to the reference resistance.
4 RS	PMOS open drain, connect to the sensor.
5 TEST1	Test pad, for IC test only.
6 OSC1	System frequency input pad.
7 OSC0	System frequency output pad.
8 BZ1	Output pad, the buffer of buzzer.
9 BZ2	Output pad, the buffer of buzzer.
10 COM1	Output pad, connect to LCD pin 1.
11 COM2	Output pad, connect to LCD pin 2.
12 COM3	Output pad, connect to LCD pin 3.
13 SA1	Output pad, connect to LCD pin 4.
14 SA2	Output pad, connect to LCD pin 5.
15 SA3	Output pad, connect to LCD pin 6.
16 SB1	Output pad, connect to LCD pin 7.
17 SB2	Output pad, connect to LCD pin 8.
18 SB3	Output pad, connect to LCD pin 9.
19 SC1	Output pad, connect to LCD pin 10.
20 SC2	Output pad, connect to LCD pin 11.
21 SC3	Output pad, connect to LCD pin 12.
22 SD1	Output pad, connect to LCD pin 13.
23 C512	Pad 23, 24 is doubler voltage 3V capacitor connects.
24 CAP	Pad 23, 24 is doubler voltage 3V capacitor connects.
25 VEE	The voltage is 3V.
26 VDD	1.5V power pad.
27 FSEL	Function select pad. No connect: for TC2156 function. Connect to VDD: for TC4367 function.
28 TEST2	Pull low test pad, for the test of production. When connect to VDD, LCD display the real-time value (not the highest value).
29 PSW	Pull low input pad, push switch to power on or power off.
30 SEL	For TC2156 function. SEL=NC: When detecting low voltage, the battery mark will blink at the speed of 1Hz. SEL=VSS: When detecting low voltage, LCD display will blink at the speed of 1Hz.

For TC4367 select buzzer alarm frequency function.

When SCR=NC or VDD:

and SEL=NC or VDD, buzzer alarm frequency is 4KHz.

SEL=VSS, buzzer alarm frequency is 5.3KHz.

When SCR=VSS:

and SEL=NC or VDD, buzzer alarm frequency is 8KHz.

SEL=VSS, buzzer alarm frequency is 6.4KHz.

- 31 CHCF No connect: °C/°F changeable mode, °C/°F can be changed by pushing switch.
- 32 SM Connect to VSS: °C/°F not changeable mode.
For TC4367 function.
SM=NC: memory function.
SM=VSS: no memory function.
For TC2156 select buzzer alarm frequency function.
When SCR=NC or VDD:
and SM=NC or VDD, buzzer alarm frequency is 5.3KHz.
SM=VSS, buzzer alarm frequency is 4KHz.
When SCR=VSS:
and SM=NC or VDD, buzzer alarm frequency is 6.4KHz.
SM=VSS, buzzer alarm frequency is 8KHz.
- 33 VSS Power pad.
- 34 SFC Select temperature show °C or °F.
No connect: °C. (When °C/°F change mode, power on is °C.)
Connect to VSS: °F. (When °C/°F change mode, power on is °F.)

.Electrical parameter:

Description		Max.	Typical	Min.
1. Operating Voltage:		1.65V	1.5V	1.25V
2. Operating Average Current:		30uA		
3. Input Voltage:	V _{IL}	V _{SS} +0.3V		
	V _{IH}			V _{DD} -0.3V
4. Output Voltage:	V _{OL}	V _{SS} +0.1V		
	V _{OH}			V _{DD} -0.1V
5. Buzzer Driving Current :(V _{ds} =1/2 V _{DD})				1mA
6. Buzzer Sinking Current:(V _{ds} =1/2 V _{DD})				1mA
7. Pull-low Resistor:	PSW Pad		300KΩ	
	TEST2 Pad		6KΩ	
	TEST1 Pad		6KΩ	

.Function description:

1 When FSEL=NC: (for TC2156)

<1> Power SW: Push switch to power on or power off.

<2> When power on:

A. The LCD display **188.8[°]F** (when SEL=NC) or **188.8[°]M** (when SEL=0) about 2 sec.

B. After A,

1. When CHCF=NC(°C/°F changeable mode):

If push switch over 2 sec, °C(°F) will change mode and only display °C (or °F) until release switch. And then memory value will not display, the step will go to the "C".

If push switch no over 2 sec, the memory value and memory's mark "M"(when SEL=0) will display 2 sec after LCD full display. Then the step will go to the "C". Power on initial is °C or °F by SFC pin option. SFC=NC, power on is °C, SFC=0, power on is °F.

2. When CHCF=0(°C/°F not changeable mode):

The °C(°F) mode is not changed by pushing switch. The °C(°F) mode is selected by SFC pin. SFC=NC is °C mode, SFC=0 is °F mode.

After LCD full display the memory value will display 2 sec. Then the step will go to the "C".

C. After B, show L °C (or °F) about 0.6 sec (don't show "M" when SEL=0).

D. After C, when it is measuring. The °C (or °F) will flash at the speed of 1Hz.

E. If the temperature < 32.0 °C (89.6 °F), then display L °C (°F).

F. If the temperature > 42.0 °C (107.6 °F), then display H °C (°F).

G. When measuring, the LCD will always display the highest temperature.

H. If the measure temperature is not changed more than 16 second, the measurement is over and mark °C(°F) flash stop.

I. When measurement is over, if the temperature > 37.5 °C (99.5 °F), the buzzer alarms "bi-bi-bi—bi-bi-bi—" for 4 sec, as follows:

Bi—————Bi—————Bi—————
 0.125s 0.125s 0.125s 0.125s 0.125s 0.375s

If the temperature ≤ 37.5 °C(99.5 °F), the buzzer alarms "bi-bi-bi-bi-" for 4 sec, as follows:

bi—————
 0.5s 0.5s

J. It will auto power off when measurement is over than 10 minutes.

K. When measurement is over, if the temperature rises within 10 min, the °C (°F) mark will flash again (repeat from the step of 2-D).

<3> When push switch, buzzer will alarm "Bi" about 0.125 sec.

<4> When power off: the stand-by current ≤ 0.5 uA.

<5> The frequency of buzzer is 4KHz/5.3KHz/6.4KHz/8KHz by pin option:

SCR pad	SM pad	buzzer frequency
NC or VDD	NC or VDD	5.3KHz
NC or VDD	VSS	4KHz
VSS	NC or VDD	6.4KHz
VSS	VSS	8KHz

<6> After <2>-A, or B-1 release switch, if detect low voltage(TT5660A:1.30 ±0.05 V, TT5660B:1.35 ±0.05 V):

A: When SEL=1 OR NC:

The battery mark "  " flashes at the speed of 1Hz and the measurement maybe not accurate, means thermometer must be changed battery.

B: When SEL=0:

The LCD display flashes at the speed of 1Hz and the measurement maybe not accurate, means thermometer must be changed battery.

<7> When TEST2 pin is connected to VDD, the LCD display the real time value not the highest value, in order to adjust the reference resistance RF during the process of producing.

<8> °C/°F(SFC Pad) power on initial function is used pad option.

	pad connect to VSS	pad no connect
SFC pad	°F	°C

<9> Thermometer others character is below:

temperature range	32.0°C ~42.0°C	89.6°F ~ 107.6°F
accuracy	±0.1 °C	±0.2 °F
resolution	0.1 °C	0.1 °F

2 When FSEL=1: (for TC4367)

<1> Power SW: push switch to power on or power off.

<2> When power on:

A. The LCD display 188.8°C (OR 188.8°F) about 2 sec. If non-memory function the "M" will not display.

B. After A,

1. When CHCF=NC(°C/°F changeable mode):

In memory function, if push switch over 2 sec, °C(°F) will change mode and only display °C (or °F) until release switch. And memory value will not display, the step will go to the "C".

That push switch no over 2 sec, the memory value will display 2 sec after LCD full display. Then the step will go to the "C". Power on initial is °C or °F by SFC pin option. SFC=NC, power on is °C, SFC=0, power on is °F.

In no memory function, the memory value will not display always.

2. When CHCF=0(°C/°F not changeable mode):

The °C(°F) mode is not changed by pushing switch. The °C(°F) mode is selected by SFC pin. SFC=NC is °C mode, SFC=0 is °F mode.

But in memory function, push switch over 2 sec will display the table-temperature of last measure and "M" until releasing switch. Then the step will go to the step "C".

No-memory function, the step will go to the step "C" after LCD full-display 2 sec.

C. After B, LCD display $36.5^{\circ}\text{C}(97.7^{\circ}\text{F})$ about 1 second.

D. After C, when it is measuring, the °C (or °F) will flash at the speed of 1Hz.

E. With pushing switch over 2 sec for changed mode or displayed the memory value, the stable-temperature time will be counted after releasing switch delayed 8 second.

Without memory function, the stable-temperature time will be counted after turn on delayed 8 second.

F. If the temperature $< 32.0^{\circ}\text{C}(89.6^{\circ}\text{F})$, then display L °C(°F).

G. If the temperature $> 44.0^{\circ}\text{C}(111.2^{\circ}\text{F})$, then display H °C(°F).

H. When measuring, the LCD will always display the highest temperature.

I. If the measure temperature is not changed more than 16 second, the measurement is over and mark °C(°F) flash stop.

J. When measurement is over, if the temperature $> 37.5^{\circ}\text{C}(99.5^{\circ}\text{F})$,

The buzzer alarms "Bi-Bi-Bi—Bi-Bi-Bi—" for 4 sec, as follows:

Bi—————Bi—————Bi—————

0.125S 0.125S 0.125S 0.125S 0.125S 0.375S

If the temperature $\leq 37.5^{\circ}\text{C}(99.5^{\circ}\text{F})$, the buzzer alarms

"Bi-Bi-Bi-Bi-" for 4 sec, as follows:

Bi—————

0.5S 0.5S

K. It will auto power off when measurement is over than 10 minutes.

L. When measurement is over, if the temperature rises within 10 minutes, then re-measure the temperature, but the °C (°F) mark will not flash again. When

re-measurement is over, the buzzer will not alarm again.

- <3> When push switch, buzzer will alarm "Bi" about 0.125 sec.
- <4> When power off: The stand-by current $\leq 0.5 \mu\text{A}$.
- <5> The frequency of buzzer is 4KHz/5.3KHz/6.4KHz/8KHz by pin option:

SCR pad	SEL pad	buzzer frequency
NC or VDD	NC or VDD	4KHz
NC or VDD	VSS	5.3KHz
VSS	NC or VDD	8KHz
VSS	VSS	6.4KHz

- <6> After <2>-B, if detect low voltage(TT5660A:1.30 \pm 0.05 V, TT5660B:1.35 \pm 0.05 V), the LCD will only display battery mark "■" and the measurement maybe not accurate, means thermometer must be changed battery.
- <7> When sensor circuit detect error, LCD only display "E", it will not measure normally until the error status cancel.
- <8> When TEST2 pin is connected to VDD, the LCD display the real-time value not the highest value, in order to adjust the reference resistance RF during the process of producing.
- <9> Memory (SM Pad) and $^{\circ}\text{C}/^{\circ}\text{F}$ (SFC Pad) power on initial function is used pad option.

	Pad connect to VSS	Pad no connect
SFC Pad	$^{\circ}\text{F}$	$^{\circ}\text{C}$
SM Pad	no memory function	memory function

- <10> Thermometer others character is below:

temperature range	32.0 $^{\circ}\text{C}$ ~44.0 $^{\circ}\text{C}$	89.6 $^{\circ}\text{F}$ ~ 111.2 $^{\circ}\text{F}$
accuracy	± 0.1 $^{\circ}\text{C}$	± 0.2 $^{\circ}\text{F}$
resolution	0.1 $^{\circ}\text{C}$	0.1 $^{\circ}\text{F}$

.LCD pattern

1 LCD connection: (For TC2156, LCD-1)

FSEL Pad: no connect
 SEL Pad : no connect (LCD-1)

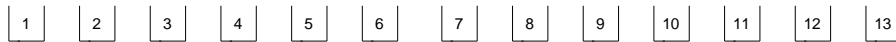
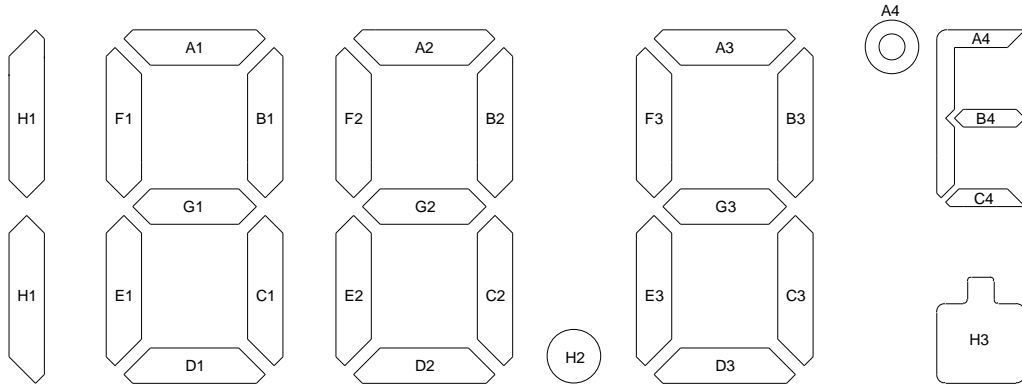

	1	2	3	4	5	6	7	8	9	10	11	12	13
COM1	COM1			F1	A1	B1	F2	A2	B2	F3	A3	B3	A4
COM2		COM2		E1	G1	C1	E2	G2	C2	E3	G3	C3	B4
COM3			COM3	H1	D1			D2	H2		D3	H3	C4

SPEC : A . 1/3 DUTY, 1/2 BIAS . (LCD USES 3 V)

B . $V_{TH} = 1.5 V$

2 LCD connection: (For TC2156, LCD-2)

FSEL Pad: no connect

SEL Pad : connect to VSS (LCD-2)

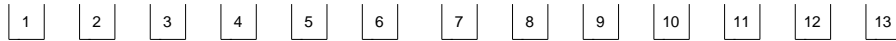
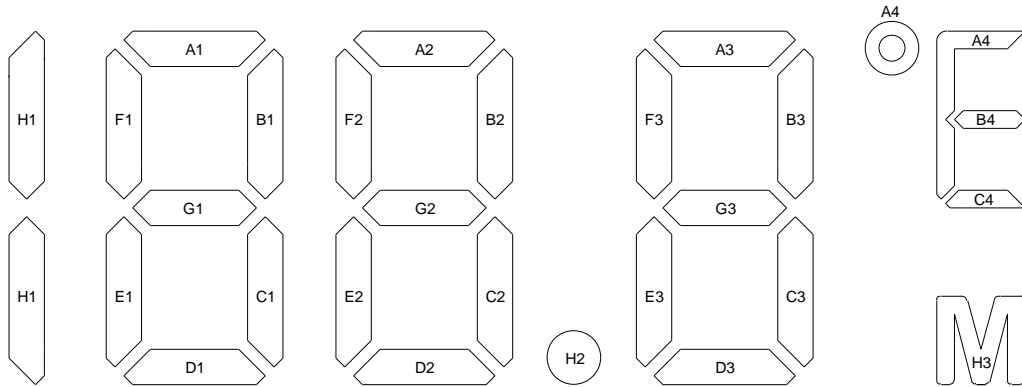

	1	2	3	4	5	6	7	8	9	10	11	12	13
COM1	COM1			F1	A1	B1	F2	A2	B2	F3	A3	B3	A4
COM2		COM2		E1	G1	C1	E2	G2	C2	E3	G3	C3	B4
COM3			COM3	H1	D1			D2	H2		D3	H3	C4

SPEC : A . 1/3 DUTY, 1/2 BIAS . (LCD USES 3 V)

B . $V_{TH} = 1.5 V$

3 LCD CONNECTION: (FOR TC4367)

FSEL Pad: connect to VDD

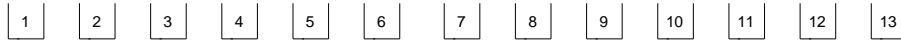
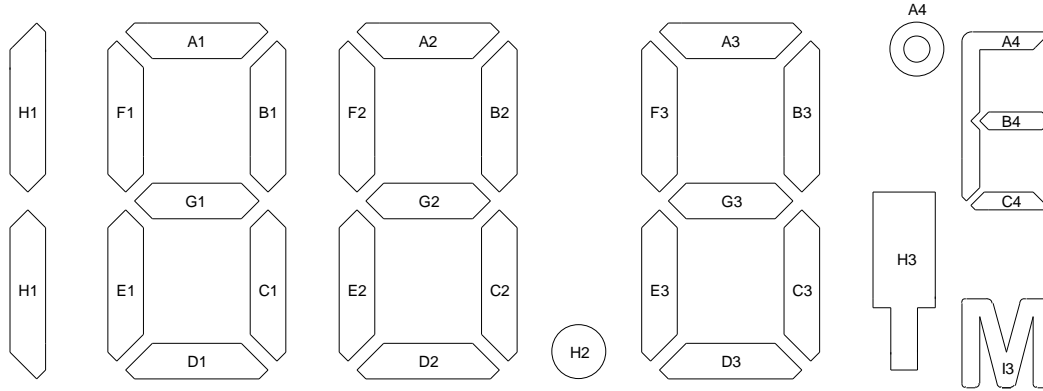

	1	2	3	4	5	6	7	8	9	10	11	12	13
COM1	COM1			F1	A1	B1	F2	A2	B2	F3	A3	B3	A4
COM2		COM2		E1	G1	C1	E2	G2	C2	E3	G3	C3	B4
COM3			COM3	H1	D1			D2	H2	I3	D3	H3	C4

SPEC : A. 1/3 DUTY , 1/2 BIAS . (LCD USES 3 V)
 B. $V_{TH} = 1.5 V$

TT5660A/TT5660B THEROMETER APPLICATION (FOR TC4367)

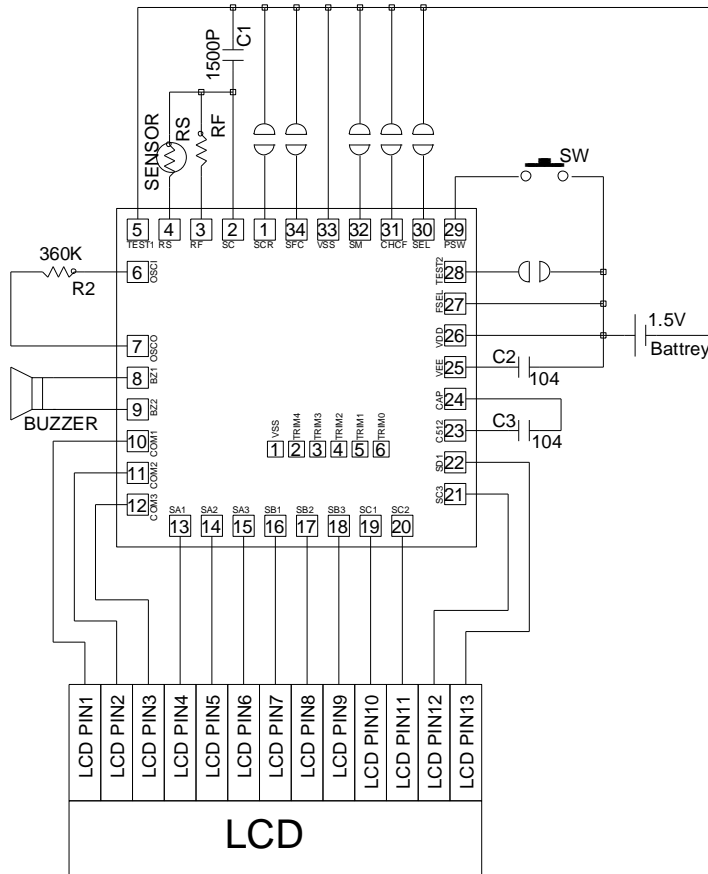

REMARK:

- (1). Sensor is use ET-503 sensor.
- (2). RF is selected according to sensor type.
- (3). About the PCB layout, recommends to do according to following methods.
 - 3-1 The R2 device should be located near the TT5660A/TT5660B IC's OSCI and OSCO pins.
 - 3-2 The lines of SC,RF,RS do not parallel and near with the lines of OSCI,OSCO.
 The space between lines of SC,RF,RS and other lines must be large as far as

(4).

CHCF pad	SFC pad	°C/°F mode
NC	NC	°C/°F changeable, power on is °C
NC	VSS	°C/°F changeable, power on is °F
VSS	NC	°C (°C/°F not changeable)
VSS	VSS	°F (°C/°F not changeable)

(5).

SCR pad	SEL pad	Buzzer frequency
NC	NC	4KHz
NC	VSS	5.3KHz
VSS	NC	8KHz
VSS	VSS	6.4KHz

(6).

SM pad	MEMORY	NO MEMORY
	NC	VSS

TT5660A/TT5660B THEROMETER APPLICATION (FOR TC4367)

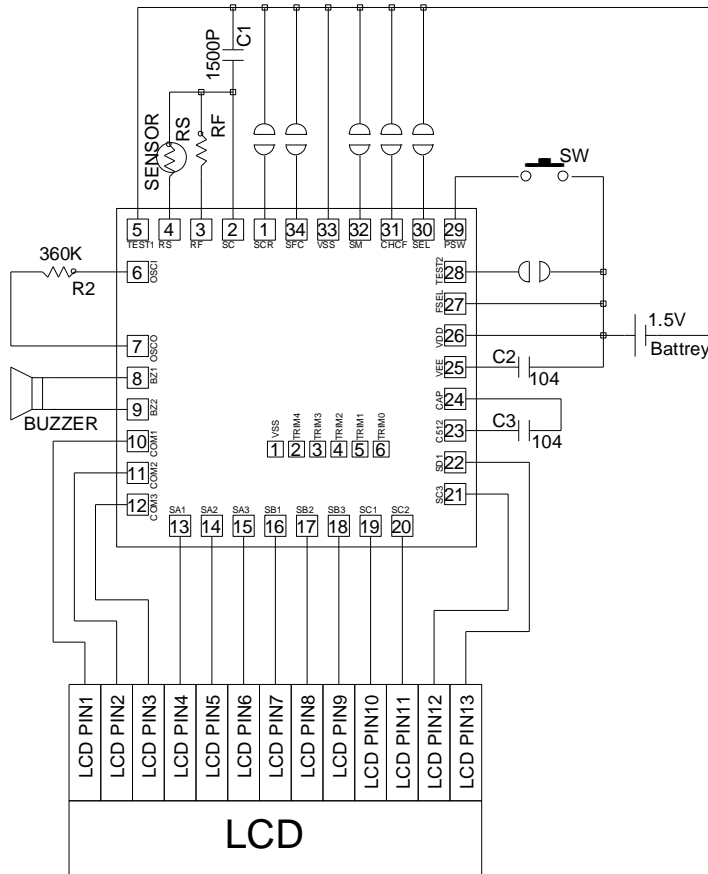

REMARK:

- (1). Sensor is use ET-503 sensor.
- (2). RF is selected according to sensor type.
- (3). About the PCB layout, recommends to do according to following methods.
 - 3-1 The R2 device should be located near the TT5660A/TT5660B IC's OSCI and OSCO pins.
 - 3-2 The lines of SC,RF,RS do not parallel and near with the lines of OSCI,OSCO.

The space between lines of SC,RF,RS and other lines must be large as far as

(4).

CHCF pad	SFC pad	°C/°F mode
NC	NC	°C/°F changeable, power on is °C
NC	VSS	°C/°F changeable, power on is °F
VSS	NC	°C (°C/°F not changeable)
VSS	VSS	°F (°C/°F not changeable)

(5).

SCR pad	SEL pad	Buzzer frequency
NC	NC	4KHz
NC	VSS	5.3KHz
VSS	NC	8KHz
VSS	VSS	6.4KHz

(6).

SM pad	MEMORY	NO MEMORY
	NC	VSS

.PAD location

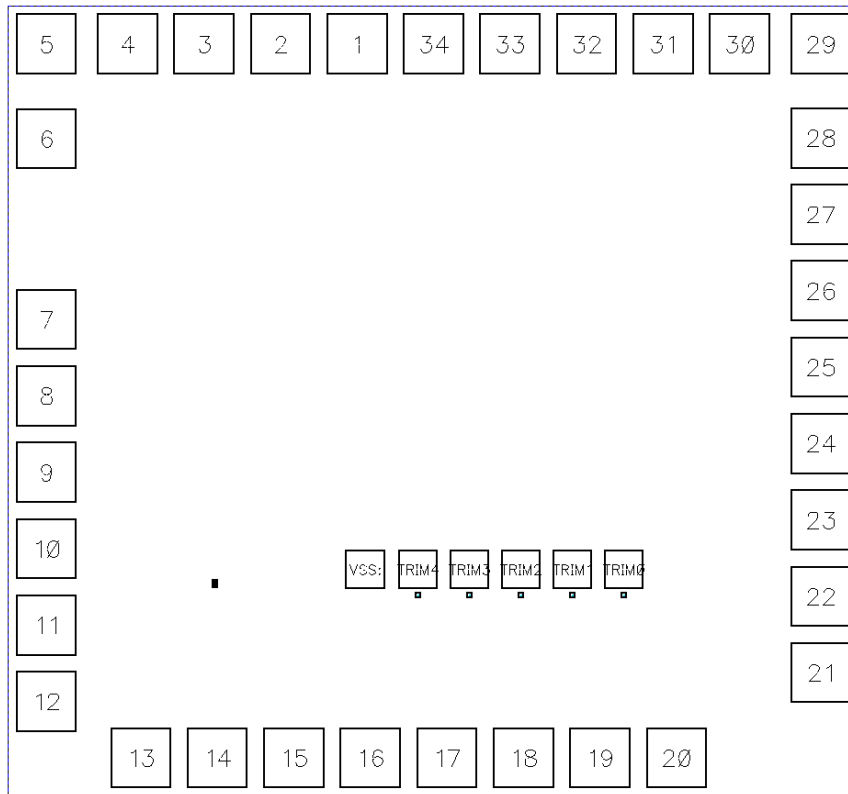

CHIP SIZE = 1370x1280 um²

SUBSTRATE floating (recommend) or VSS

*****				*****			
NO	NAME	X=	Y=	NO	NAME	X=	Y=
*****				*****			
1	SCR	-116.00	541.50	18	SB3	136.20	-542.50
2	SC	-232.00	541.50	19	SC1	252.20	-542.50
3	RF	-348.00	541.50	20	SC2	368.20	-542.50
4	RS	-464.00	541.50	21	SC3	587.00	-413.20
5	TEST1	-587.00	541.50	22	SD1	587.00	-297.20
6	OSCI	-587.00	397.80	23	C512	587.00	-181.20
7	OSCO	-587.00	123.10	24	CAP	587.00	-65.20
8	BZ1	-587.00	7.10	25	VEE	587.00	50.80
9	BZ2	-587.00	-108.90	26	VDD	587.00	166.80
10	COM1	-587.00	-224.90	27	FSEL	587.00	282.80
11	COM2	-587.00	-340.90	28	TEST2	587.00	398.80
12	COM3	-587.00	-456.90	29	PSW	587.00	541.50
13	SA1	-443.80	-542.50	30	SEL	464.00	541.50
14	SA2	-327.80	-542.50	31	CHCF	348.00	541.50
15	SA3	-211.80	-542.50	32	SM	232.00	541.50
16	SB1	-95.80	-542.50	33	VSS	116.00	541.50
17	SB2	20.20	-542.50	34	SFC	0.00	541.50
*****				*****			

.ORDER INFORMATION

1. for TT5660A:
 - a. Package form: No support
 - b. Chip form: TC5660A
 - c. Wafer base: TD5660A
2. for TT5660B:
 - a. Package form: No support
 - b. Chip form: TC5660B
 - c. Wafer base: TD5660B

.TC8492A and TT5660A/TT5660B function difference explanation

1. The position of SC PAD and SCR PAD just exchanges in the TT5660A/TT5660B and TC8492A. Therefore originally uses TC8492A PCB, must pay attention in TT5660A/TT5660B SC PAD already exchange with SCR PAD, when TT5660A/TT5660B IC bond wire. Please refer to the PAD LOCATION.
2. The SCR PAD uses to select the buzzer frequency in TT5660A/TT5660B, the detailed function please refer to the application circuit diagram.
3. In TT5660A/TT5660B the CHCF PAD uses to select that °C/°F mode can be changed or not by pushing switch, the detailed function please refer to the application circuit diagram.
4. TT5660A/TT5660B built-in low voltage detect (LVD) circuit, PCB application save 1 resistor and improve ability which the low voltage detects, lets TT5660A/TT5660B the low voltage function be stable.
5. Has strengthens IC the ESD protection capability.

.REVISE HISTORY

1. 2008/09/30
-Original version : V_1.0
2. 2008/12/2
-Add TT5660B
3. 2009/12/3 -version : V_1.2
Revise page 7, page9 CFCH string to CHCF
4. 2014/06/06 -version : V_1.3
Revise page 14,15 application, add REMARK(3) : PCB layout recommends matter.